

HydroTherm®

AM SERIES

MULTIPULSE®

INSTALLATION

MANUAL



**FOR COMMERCIAL INSTALLATIONS SEE
PART I – PAGES 1 - 32**

**FOR RESIDENTIAL INSTALLATIONS
PART II – SEE PAGES 33 - 55**



PART I – COMMERCIAL INSTALLATION TABLE OF CONTENTS

SECTION 1: INTRODUCTION		SECTION 5: CONDENSATE LINE..... 18	
AM-100 & 150 Dimensions.....	3	SECTION 6: INSTALLING GAS PIPING	
AM-300 Dimensions.....	4	Connecting Piping.....	19
SECTION 2: LOCATING/SETTING BOILERS.....	5	Testing Gas Piping.....	19
SECTION 3: INSTALLING WATER PIPING		SECTION 7: WIRING.....	20
Planning Ahead.....	8	SECTION 8: START-UP & OPERATION	
Piping Tree Components.....	8	Sequence of Operation.....	24
Water Piping & Headers.....	9	Purging & Start-Up.....	25
Hydronic Components.....	10	Operation Adjustments.....	25
Hydrotesting System.....	12	SECTION 9: TROUBLESHOOTING.....	27
SECTION 4: VENTING THE BOILERS		APPENDICES	
Planning Ahead.....	12	A: Gas Pipe Sizing.....	28
Dormant Chimney.....	14	B: Control Guidelines.....	29
Through-The-Roof.....	15	WARRANTY	59
Through-The-Wall.....	17		

SECTION 1: INTRODUCTION

HEATING PLANT DESIGN

The Pulse boiler is an advanced technology, high efficiency, automatic, gas fired, direct vent water boiler which utilizes the pulse combustion principle. As such, it requires no burners, no pilot flame, no flue and no chimney. For combustion, the boiler uses 100% outside air, supplied through Schedule 40 Poly Vinyl Chloride (PVC) pipe. The products of combustion are vented to the outdoors through Schedule 40 Chlorinated Poly Vinyl Chloride (CPVC) pipe. Pipe can be routed either through a dormant chimney, a roof or an outside wall.

Gas and water connections are similar to conventional boiler systems; however, **DO NOT ATTEMPT TO START BOILER, EVEN MOMENTARILY, BEFORE FILLING AND PURGING BOILER AND SYSTEM AS A DRY-FIRE CONDITION WILL RESULT IN BOILER DAMAGE WHICH IS NOT COVERED BY THE WARRANTY.**

The Pulse boiler is covered by the following U.S. Patents: 3,267,985; 4,241,720 and 4,241,723.

Modular Pulse heating plants are comprised of individual modules that are piped to common headers to provide large hot water heating capacities. They are designed and intended for use as a central space heating system, for volume water heating, or for combination space heating/volume water heating. Each module is self-contained with its own set of controls and can operate independently of the other modules.

The objective of a modular heating plant control system is to relate plant output to actual heating load by automatic step-firing. This means that more or fewer heating modules are operated in response to an increase or decrease in actual heating load. Hydrotherm has developed three basic methods (levels) of control which meet most operating requirements encountered. Typical wiring diagrams for these basic methods are provided in Appendix B - Part I of this manual. Special control system designs can be developed through the Hydrotherm applications engineering group.

CODE COMPLIANCE

Installations must conform to requirements of authority having jurisdiction or, in absence of such requirements, to National Fuel Gas Code ANSI Z223.1-latest edition. Where

required by authority having jurisdiction, installation must also conform to Standard for Controls & Safety Devices for Automatically Fired Boilers, ANSI/ASME – CSD-1.

All electrical wiring must be in accordance with the requirements of authority having jurisdiction or, in absence of such requirements, with National Electric Code NFPA -70-latest edition and any additional state or local code requirements. If an external source is utilized, installed boiler must be electrically grounded in accordance with the requirements of authority having jurisdiction or, in absence of such requirements, with National Electric Code ANSI/NFPA-70 – latest edition. UL listed power limited circuit cable is almost universally approved for safety controls on heating equipment, either internally or externally, without protection of conduits or raceway.

For Canada, the installation must be in accordance with Standards CAN/CGA B149.1 or .2 Installation Codes for Gas Burning Appliances and Equipment and with Standard C.S.A. C22.1 Canadian Electrical Code, Part 1 and Part 2, and/or local codes.

WARNING: Installers must follow local regulations with respect to the installation of CO detectors and follow the manufacturer's stated maintenance schedule for this boiler!

ATTENTION: Observer les règlements régional à l'égard des détecteurs de monoxyde de carbone et observer entretien de manufacturier pour cette chaudière!

HEATING PLANT SHIPMENT

Each boiler is shipped in a single carton and weighs 265 lbs (AM-100), 436 lbs. (AM-150) or 872 lbs. (AM-300). A supply water piping tree assembly with a temperature/ pressure indicator and pressure relief valve is packed with each boiler.

For modular Pulse heating plants, control equipment such as modulating aquastats, diverting valves, step controllers, etc. are furnished in separate cartons when ordered with boilers.

The following terms are used throughout this manual to bring attention to the presence of potential hazards or to important information concerning the product:

DANGER: Indicates an imminently hazardous situation which, if not avoided, will result in death, serious injury or substantial property damage.

WARNING: Indicates a potentially hazardous situation which, if not avoided, could result in death, serious injury or substantial property damage.

CAUTION: Indicates a potentially hazardous situation which, if not avoided, may result in minor injury or property damage.

NOTE: Used to notify of special instructions on installation, operation or maintenance which are important to equipment but not related to personal injury hazards.

BOILER MODEL	DIMENSIONS (INCHES)												
	A	B	C	D	E	F	G	H	J	K	L	M	N
AM-100	40"	14"	5-5/8"	35-1/2"	10-3/8"	43-1/2"	1"	1-1/2"	23-1/2"	1-1/2"	16"	50"	25-3/4"
AM-150	47-1/4"	17"	4"	42-11/16"	14-1/8"	51-3/4"	1-1/4"	2"	27"	1-5/8"	23-3/4"	58"	30-3/4"

INLET AIR (H) (AM-100 & 150)
 EXHAUST AIR (H) (AM-150 ONLY)

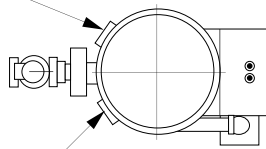

EXHAUST AIR (H) (AM-100 ONLY)

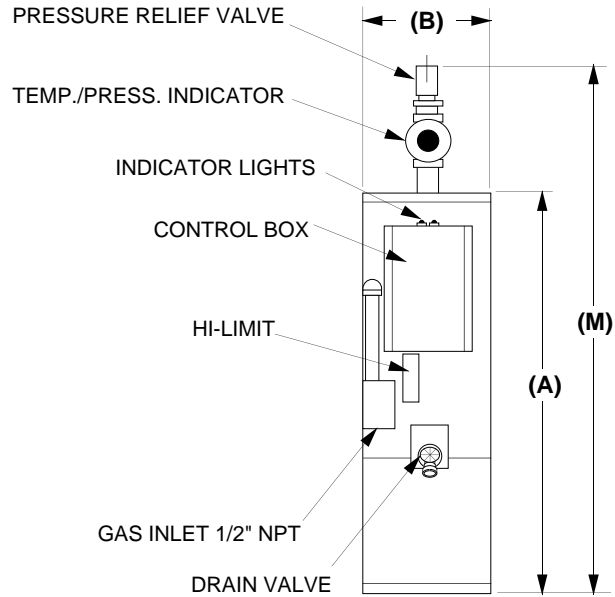
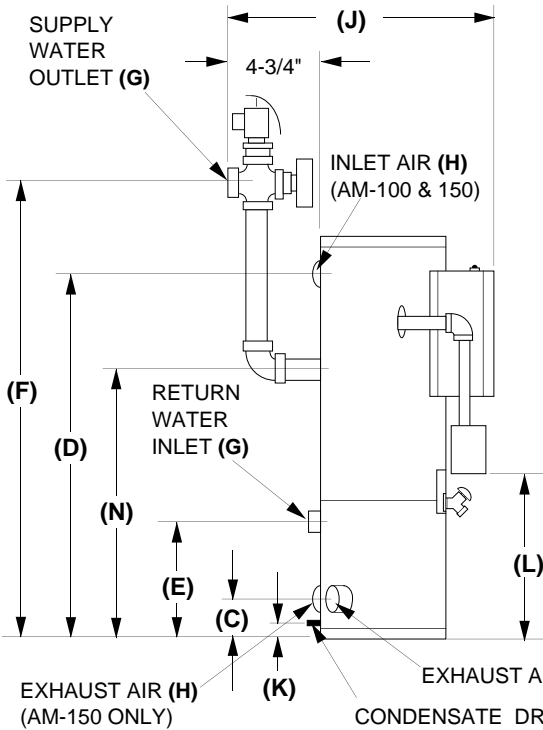

NO. OF MODULES	2	3	4	5	6	7	8	9	10	11	12"
LENGTH "L" (AM-150)	3' 4"	5' 3"	7' 2"	9' 1"	11' 0"	12' 11"	14' 10"	16' 9"	18' 8"	20' 7"	22' 6"
LENGTH "L" (AM-100)	2' 10"	4' 6"	6' 2"	7' 10"	9' 6"	11' 2"	12' 10"	14' 6"	16' 2"	17' 10"	19' 6"

* Over 12 modules add 23" per unit to "L" (AM-150)

* Over 12 modules add 20" per unit to "L" (AM-100)

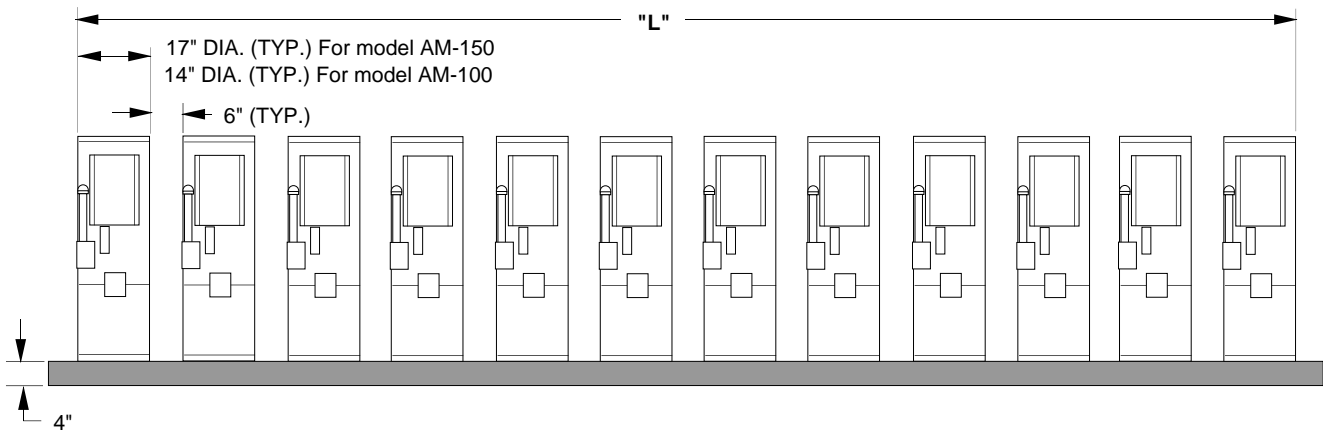

MODELS AM-100 & AM-150 DIMENSIONS

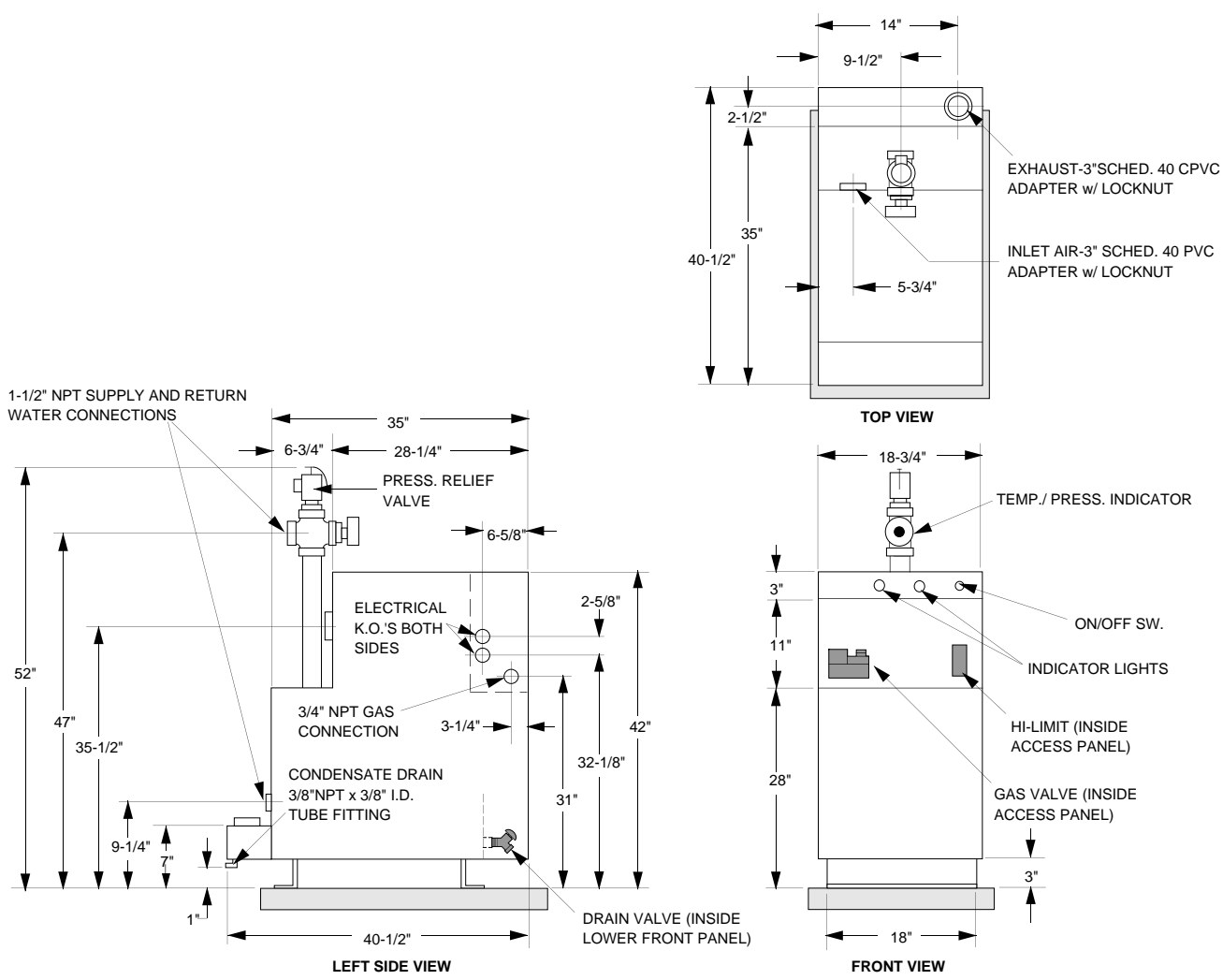

NO. OF MODULES	2	3	4	5	6	7	8
LENGTH "L"	3' 7-3/4"	5' 8-3/4"	7' 9-3/4"	9' 10-3/4"	11' 11-3/4"	14' 3/4"	16' 1-3/4"

* Over 8 modules add 25" per unit to "L"

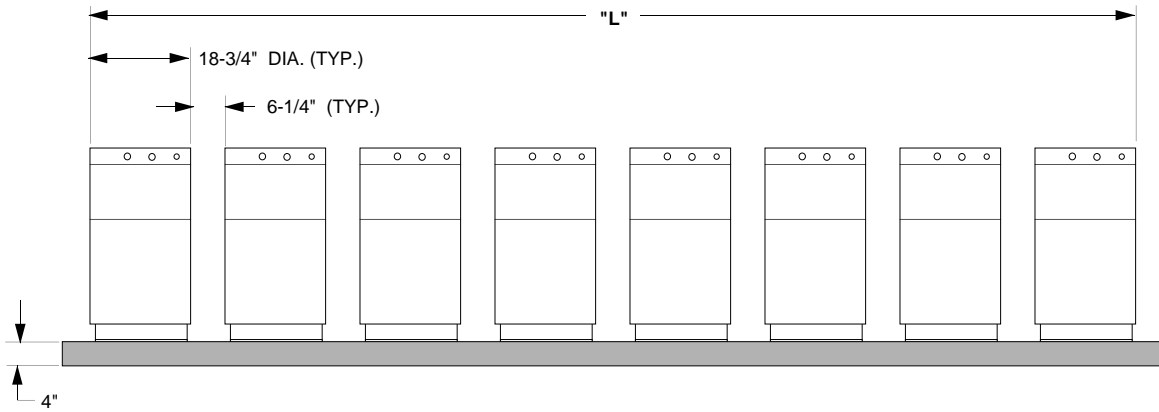

MODEL AM-300 DIMENSIONS

SECTION 2: LOCATING & SETTING BOILERS

Pulse modular heating plants can be tailored to the area and shape of rooms simply by grouping individual modules, as shown in examples in Figures 2.2. Recommended clearances, which are more than combustible clearances, allow for servicing, installation, and connections. For back-to-back installations, if shop drawings with approved layouts are not available, use recommended clearances shown in Figures 2.3 through 2.7.

WARNING: Never install boiler on carpeting.

Observe the minimum clearances to combustibles as shown in Figure 2.1. Local requirements may specify greater clearances and must be adhered to. All units are approved for installation on combustible flooring.

DO NOT install this boiler in a location that would subject any of the gas ignition components to direct contact with water or excessive moisture during operation or servicing.

Air intake & exhaust pipe sizes, piping runs between boilers and the outdoors and vent terminations must be in accordance with the venting requirements detailed in Section 4 in this manual.

Never install boilers or vent piping, except terminations, in an unconditioned area where condensate will be subject to freezing temperatures.

BOILER MODEL	Minimum Clearances To Combustibles (In.)			
	TOP	FRONT	SIDES	REAR
AM-100	24"	6"	0"	0"
AM-150	24"	6"	0"	0"
AM-300	24"	"ALCOVE"	2"	2"

* INDICATES USA/CAN APPROVED CLEARANCES

FIGURE 2.1

Solid pedestals, to support boiler weight, will be required if an in-the-floor drain is not available to collect condensate. The pedestal must be of sufficient height to permit gravity draining of condensate.

Resilient pads under the boilers are recommended for installations in or above a living space to reduce vibrations being transmitted into floor or living space.

Because of their weight and the importance of protecting internal components, always use a good hand truck to move the boilers.

CAUTION: Avoid any excessive bouncing when moving boilers down a stairwell.

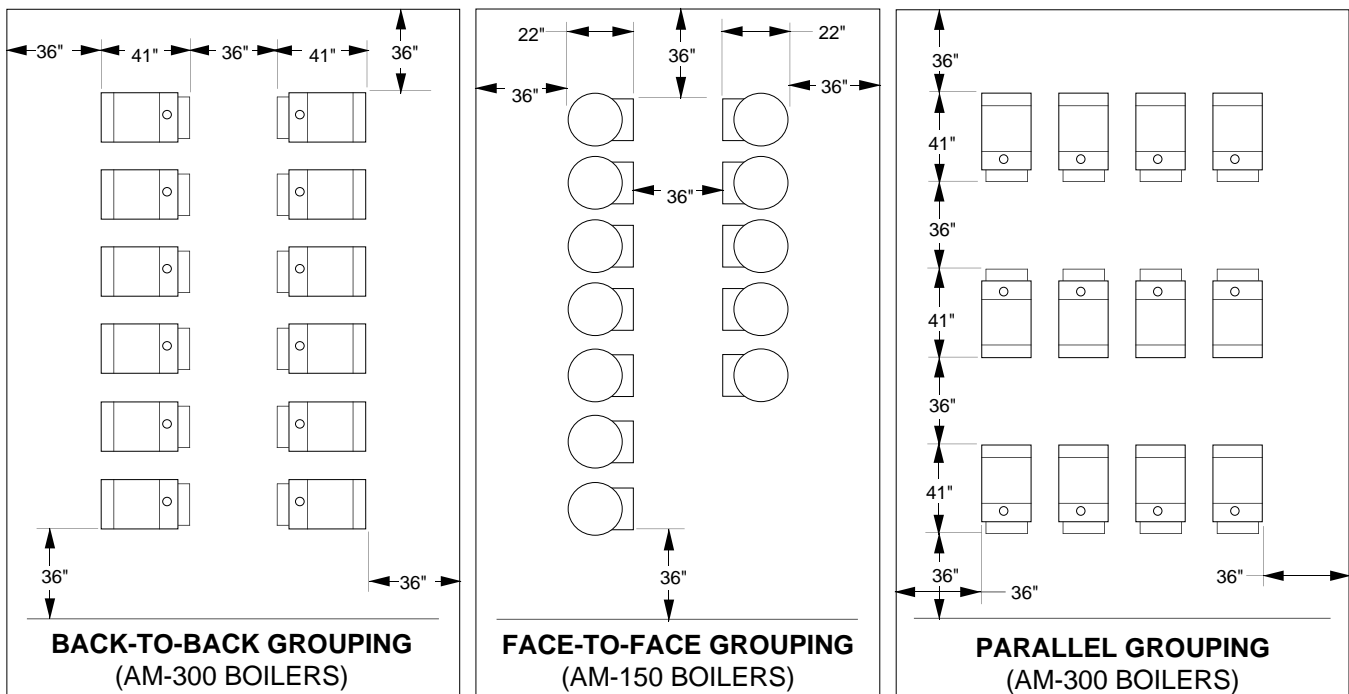

FIGURE 2.2

MODULAR BOILER ARRANGEMENT EXAMPLES

NOTE: WHEN INDIVIDUAL STOP VALVES ARE TO BE INSTALLED IN EACH BOILER'S SUPPLY & RETURN, ALLOW ADEQUATE SPACE.

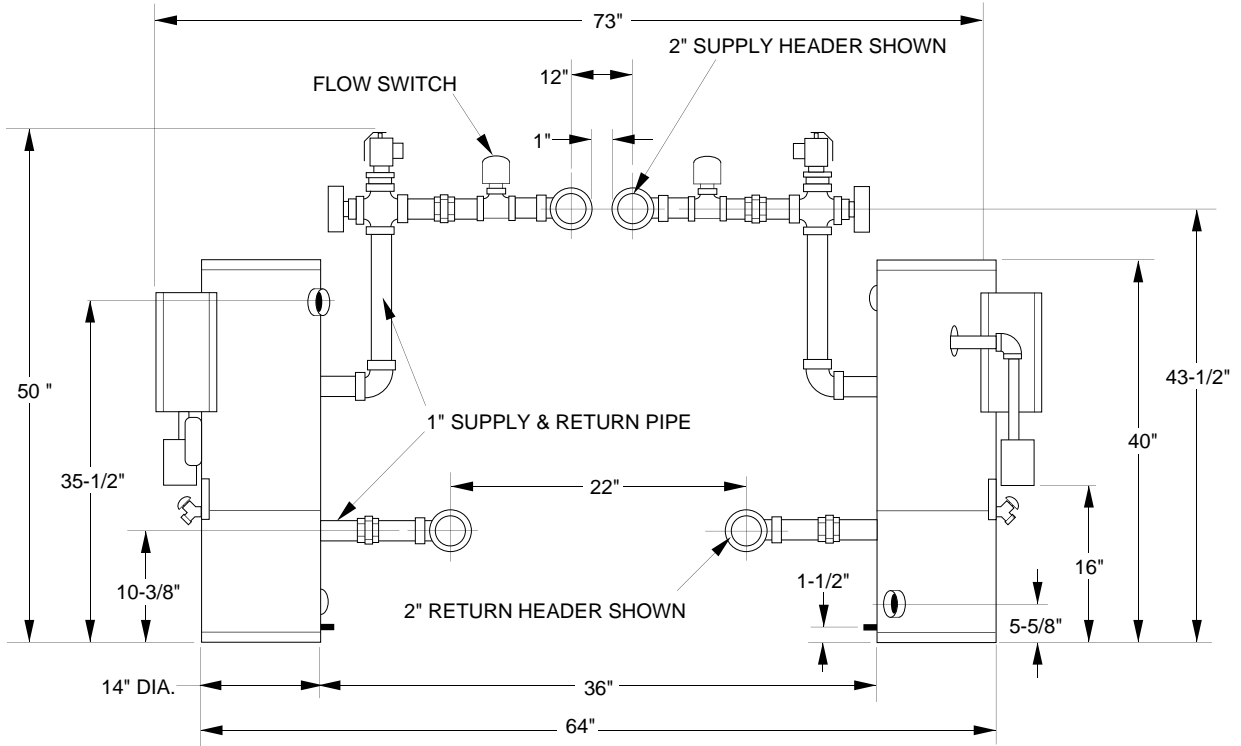

FIGURE 2.3: MODEL AM-100 BACK-TO-BACK ARRANGEMENT WITH SUFFICIENT SPACE

NOTE: WHEN INDIVIDUAL STOP VALVES ARE TO BE INSTALLED IN EACH BOILER'S SUPPLY & RETURN, ALLOW ADEQUATE SPACE.

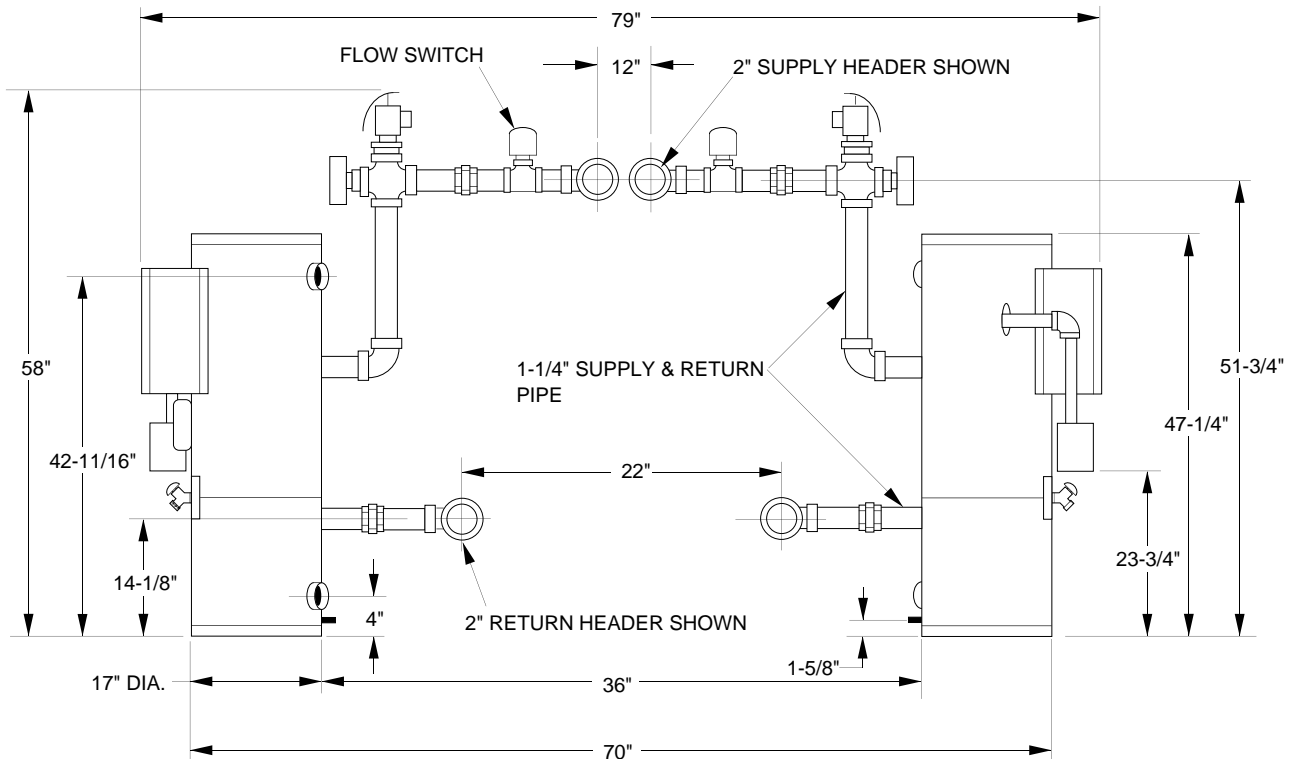

FIGURE 2.4: MODEL AM-150 BACK-TO-BACK ARRANGEMENT WITH SUFFICIENT SPACE

MODULAR BOILER ARRANGEMENT EXAMPLES

NOTE: WHEN INDIVIDUAL STOP VALVES ARE TO BE INSTALLED IN EACH BOILER'S SUPPLY & RETURN, ALLOW ADEQUATE SPACE.

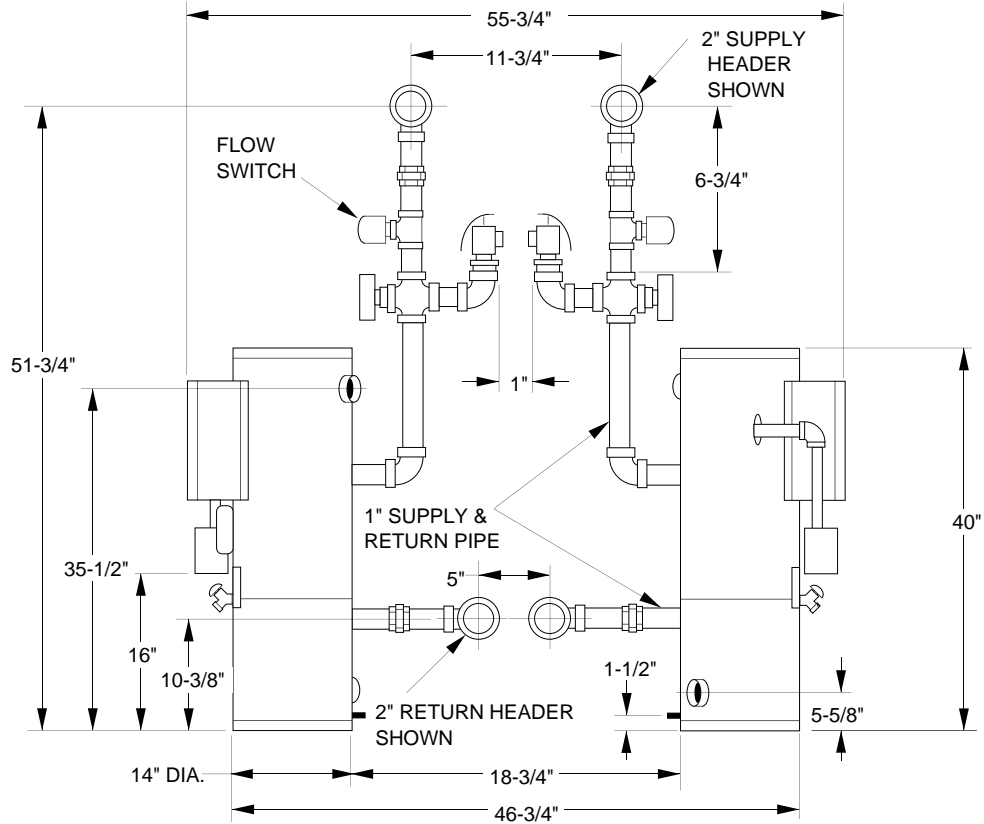

FIGURE 2.5: MODEL AM-100 BACK-TO-BACK ARRANGEMENT FOR TIGHT SPACE

NOTE: WHEN INDIVIDUAL STOP VALVES ARE TO BE INSTALLED IN EACH BOILER'S SUPPLY & RETURN, ALLOW ADEQUATE SPACE.

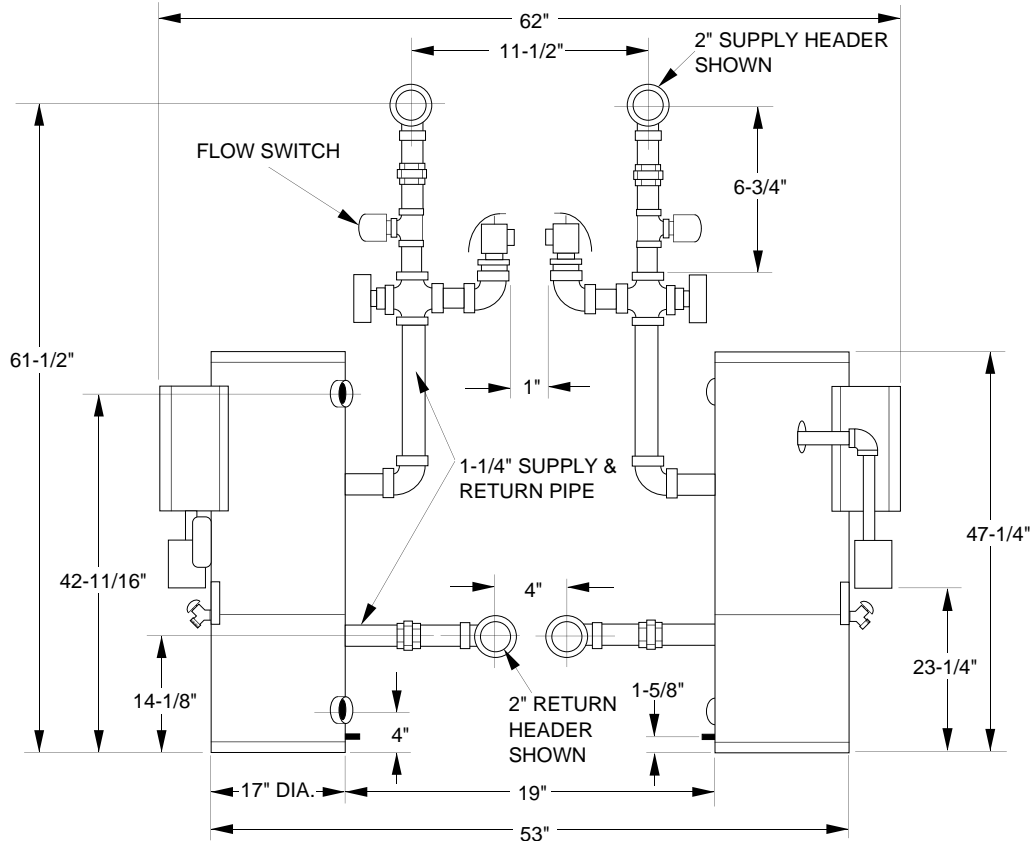
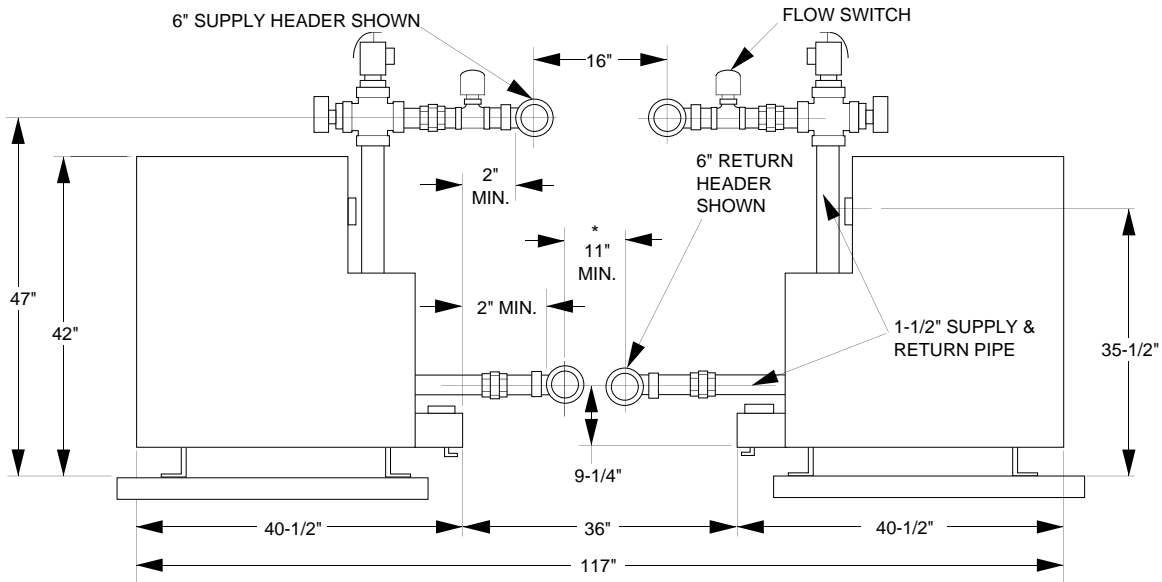

FIGURE 2.6: MODEL AM-150 BACK-TO-BACK ARRANGEMENT FOR TIGHT SPACE

MODULAR BOILER ARRANGEMENT EXAMPLE

NOTE: WHEN INDIVIDUAL STOP VALVES ARE TO BE INSTALLED IN EACH BOILER'S SUPPLY & RETURN, ALLOW ADEQUATE SPACE.



*Minimum recommended clearances where space is adequate. Where space is unusually tight, these dimensions may be reduced slightly by installing boilers and return headers fitting-to-fitting.

FIGURE 2.7: MODEL AM-300 BACK-TO-BACK BOILER ARRANGEMENT

SECTION 3: INSTALLING WATER PIPING

PLANNING AHEAD

WATER TREATMENT: Recommended where water quality is a problem; must be used in hard water areas & on very large volume heating systems. Local water treatment company should be consulted to determine requirements for your system and locality.

NOTE: Boilers not for use in systems where water is replenished. Minerals in water can build up on heat transfer surfaces and cause overheating and subsequent failure of the heat exchanger.

FREEZE PROTECTION: Where it's necessary, anti-freeze can be used but must be compatible with hydronic systems. System must be designed to accommodate necessary changes in heat transfer, pump head, flow rate, and expansion. Consult The Hydronics Institute Technical Topics Number 2A publication.

NOTE: Never use an RV-type anti-freeze protection solution nor an automotive-type antifreeze as damage to boilers and other system components may result.

ASSEMBLE PIPING TREE COMPONENTS

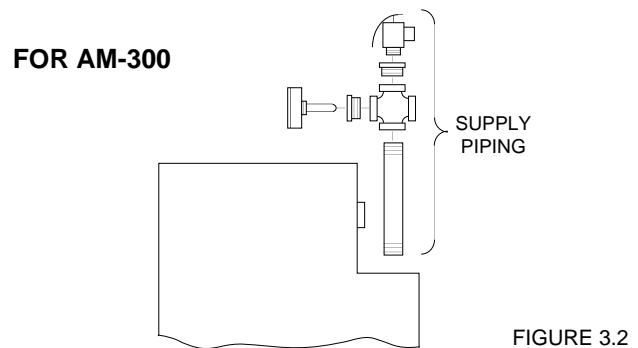
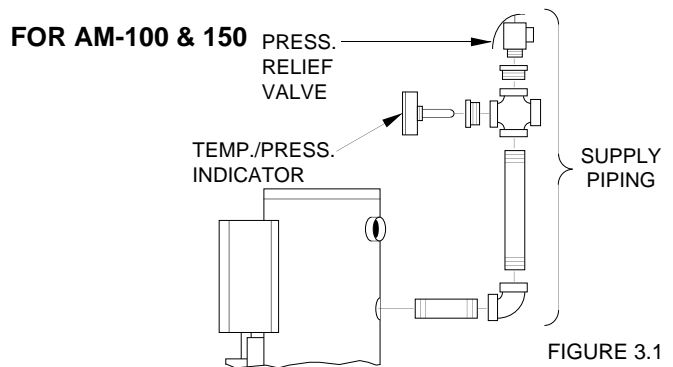

INSTALL WATER PIPING & HEADERS

Unlike conventional boilers, modular Pulse boilers must not be allowed to fire unless minimum water flow rates, as shown in Figure 3.3, are provided to EACH boiler under all system operating conditions. As a general rule for hydronic systems, design water flow rate should be based on 20° F temperature rise through the boiler plant. A 40° F rise is the minimum. Irreparable damage to boilers will result if the recommended flow rates are not maintained.

Existing heating systems being retrofitted with Pulse boilers should be thoroughly evaluated to determine if a low or no-flow rate situation could exist under any operating condition such as zone valves or zone circulators shutting down the flow. If such a situation exists, there are a number of ways of ensuring that minimum flow rates are maintained. Install primary/secondary circulators and bypass loops, circulators, and/or flow switches. Installer must ensure operation of the heating system components will not result in a lack of flow to the boiler plant.

Individual modules must be joined together with field-fabricated pipe headers. If shop drawings with approved header sizes are not available, use sizing guidelines recommended in Figure 3.4.

HEADERS MUST BE INSTALLED TO PROVIDE REVERSE RETURN FLOW, as shown in Figures 3.5 and 3.6. This will assure balanced water flow through all modules.

Boiler Model	Fuel	Input (Mbh)	Heat Cap. (Mbh)	Water Flow - (Gpm)	
				System Design ΔT (°F)	
				20	40
AM-100	NG	100	88.0	8.8	4.4
	LP	90	80.0	8.0	4.0
AM-150	NG	150	132.0	13.2	6.6
	LP	135	122.0	12.2	6.1
AM-300	NG	299	272.0	27.2	13.6

FIGURE 3.3

Appliances installed in high altitude elevations require derating for which output criteria should be compensated appropriately. Refer to "Operation Adjustments" section for derating procedure.

NO. OF MODULES			GPM (1)	PIPE SIZE (IN.)(2)
AM-100	AM-150	AM-300		
2	-	-	18	1-1/2"
3	2	1	27	2"
4	-	-	36	
-	3	-	40.5	2-1/2"
5	-	-	45	
6	4	2	54	
7	-	-	63	3"
-	5	-	67.5	
8	-	-	72	
9	6	3	81	
10	-	-	90	
-	7	-	94.5	
11	-	-	99	
12	8	4	108	4"
13	-	-	117	
-	9	-	121.5	
14	-	-	126	
15	10	5	135	
16	-	-	144	
-	11	-	148.5	
17	-	-	153	6"
18	12	6	162	
19	-	-	171	
-	13	-	175.5	
20	-	-	180	
21	14	7	189	
22	-	-	198	
-	15	-	202.5	
23	-	-	207	
24	16	8	216	

(1) Based on 20°F ΔT (2) Based on maximum velocity of 5ft/sec.

FIGURE 3.4

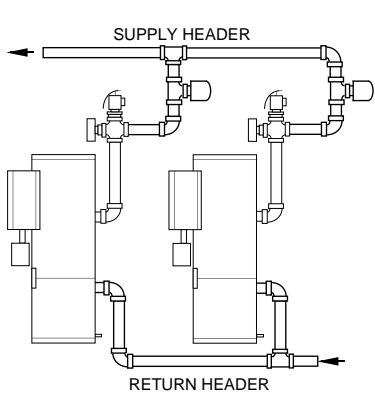

FIGURE 3.5

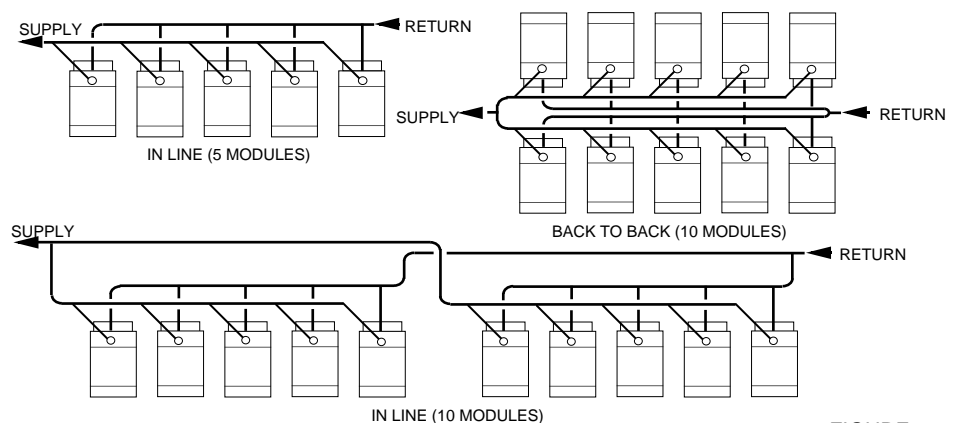

FIGURE 3.6

INSTALL HYDRONIC COMPONENTS

Figures 3.7 and 3.8 show typical locations of hydronic components required for Pulse modular heating plants. In all cases, installation should be in accordance with component manufacturer's recommendations. Literature, if applicable, is packaged with each component. In addition, following guidelines should be used:

VIBRATION ISOLATORS: Use braided metal hose or reinforced rubber type; working pressure and temperature rating must be greater than that of the operating system. Install vibration isolators at both the supply and return water header connections.

PRESSURE RELIEF VALVES: One is supplied for each boiler. Should have been installed with supply water piping tree with spindle in vertical position, valve discharge in horizontal. Install field-supplied relief valve discharge piping, which must be same size or larger than valve outlet & terminate 6" above floor.

WARNING: No valve of any type may be installed between the modules and the relief valve or an explosion from over-pressurization may occur!

CAUTION: Piping must be installed from the relief valve discharge so there will be no danger of scalding personnel.

TEMPERATURE/PRESSURE INDICATORS: One is supplied for each boiler. Should have been installed with supply water piping tree.

AIR SEPARATOR: Locate in the supply line between boiler and system pump where it will protect all modules under all operating conditions. Follow manufacturer's installation instructions.

AIR ELIMINATOR: Install on air separator where it will protect all modules under all operating conditions. Follow manufacturer's installation instructions.

EXPANSION TANK: Locate on suction side of pump where it will protect all modules under all operating conditions. Follow manufacturer's instructions.

PRESSURE REDUCING (FILL) VALVE: Follow manufacturer's installation instructions.

LOW WATER CUTOFF: (Electronic type or float type) Locate in supply header. Follow manufacturer's installation instructions. If heating plant is to be installed above the level of radiation, low water cut-off must be installed to protect heating plant from dry fire.

CAUTION: To prevent accidental dry fire, do not install isolation valves between low water cutoff and the boiler.

CAUTION: Do not install any low water cut-off in a location where water will not freely drain away from the float or probe such as in a pipe tree or loop, should a low water condition develop in the module.

For electronic probes, a vertical installation where all water can freely drain away from probe is preferred over horizontal. Do not install in small diameter pipe nipples or bushings, as insufficient clearance to probe may result in corrosion and/or erroneous readings.

MANUAL RESET HI-LIMIT: Locate in supply piping downstream of connection of the last module.

SYSTEM PUMP: Must be selected for system design flow rate and anticipated head loss through the piping system. Locate in boiler or heating plant supply piping, downstream of the modules. Follow manufacturer's installation instructions.

NOTE: Heating plant must not be used without forced circulation, as overheating/failure of heat exchanger may result.

DIVERTING VALVE: Commonly used on combination space/volume water heating systems where flow of boiler water from a single module is being diverted from space heating to storage tank water heating coil or external heat exchanger. Use a V8044E 1011 w/end switch for single AM-100 & 150; larger valve required for AM-300 and where multiple boilers are diverted. Follow manufacturer's instructions.

FLOW CHECK VALVE (Optional): Important to control direction of flow and prevent gravity circulation. Locate where it cannot cause isolation of any particular loop or zone from the main system. Follow manufacturer's installation instructions.

MAKE-UP WATER METER (Optional): Will help determine total system water volume for purposes of water treatment, and aid in the identification of a system leak. Follow manufacturer's installation instructions.

STRAINER (Optional): For retrofit or steam conversion systems, basket-type strainer will trap loose system scale. Locate in return water line. Follow manufacturer's installation instructions.

BACKFLOW PREVENTER (Optional): Used as a means of isolation (space heating system from main water supply) to safeguard against potential hazard of fill valve connection allowing migration of water treatment chemicals into the potable water supply. Follow manufacturer's installation instructions.

TYPICAL PIPING FOR MODULAR SPACE HEATING SYSTEM

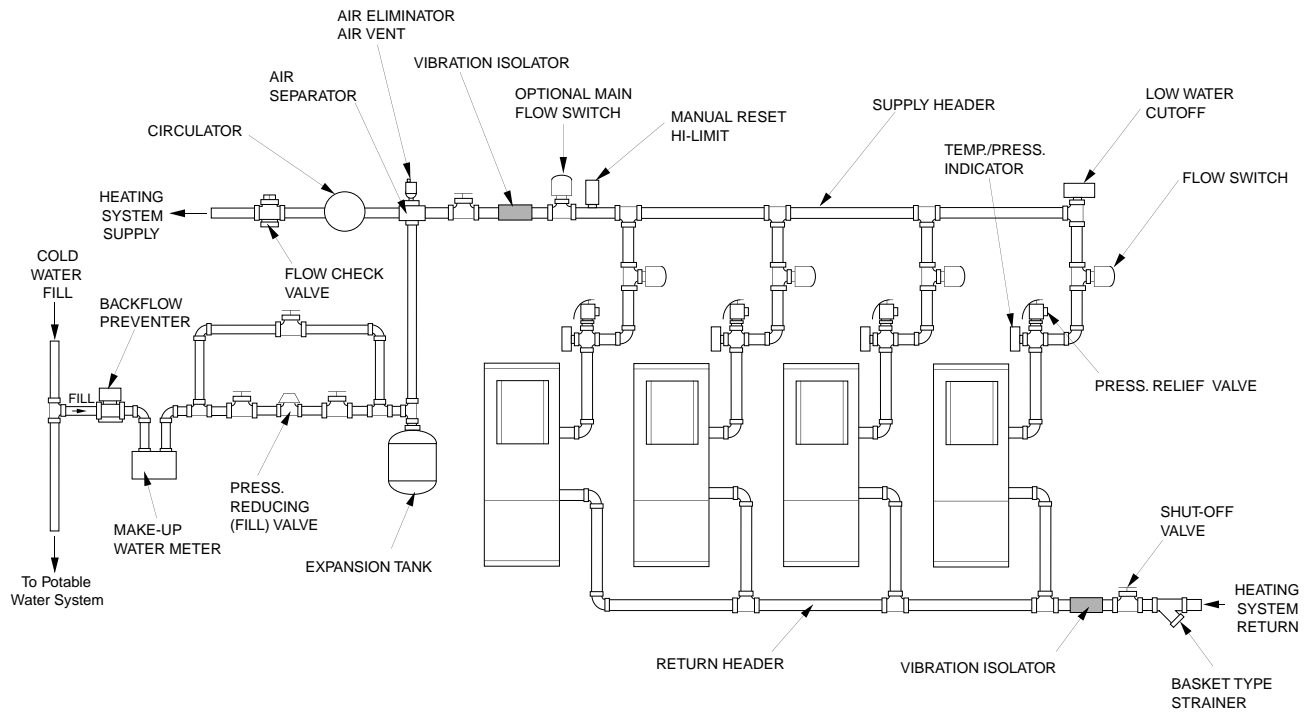

FIGURE 3.7

TYPICAL PIPING FOR MODULAR COMBINATION SPACE HEATING & VOLUME WATER HEATING SYSTEM

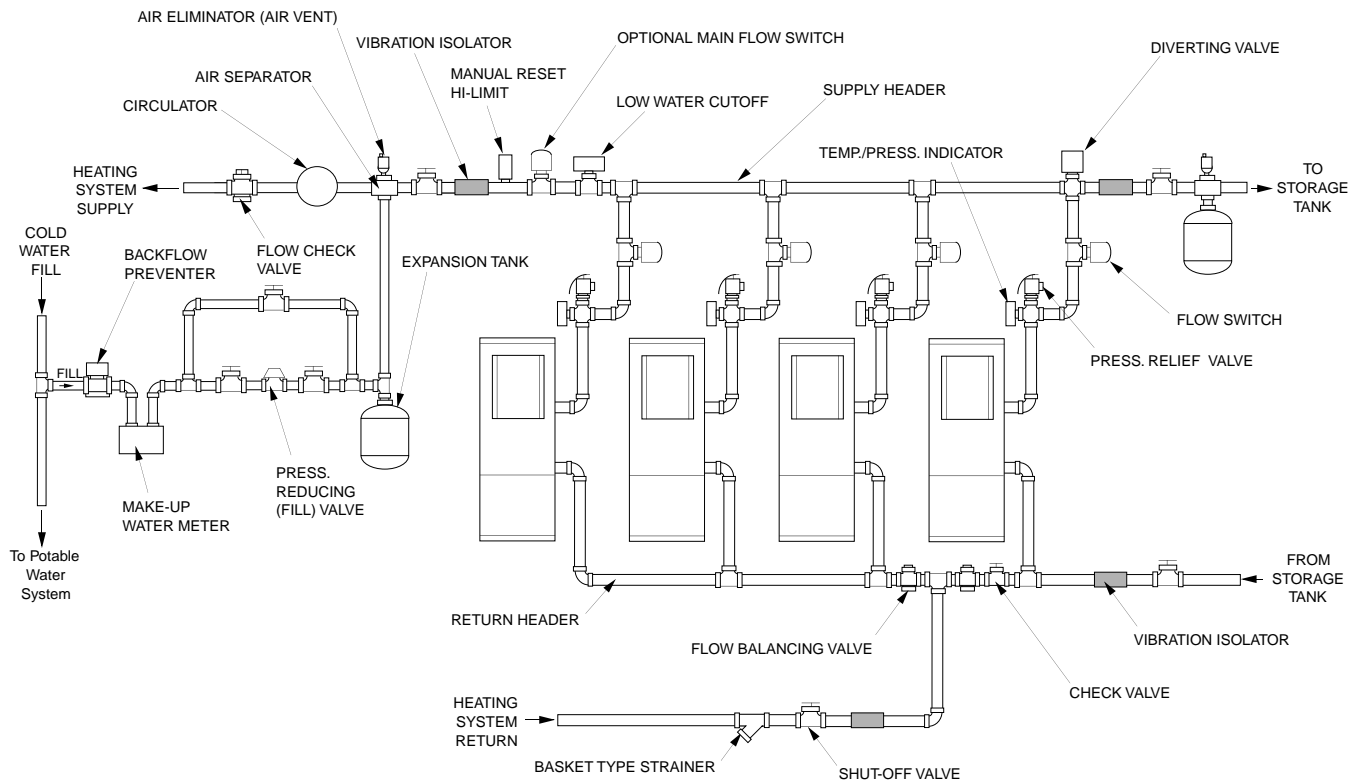

FIGURE 3.8

INSTALL HYDRONIC COMPONENTS (continued)

FLOW SWITCH: Flow switches are required to prevent heat exchanger damage due to leaks or insufficient water flow. Follow the manufacturer's installation instructions. Install in horizontal position.

OTHER COMPONENTS: Install all other waterside components such as manual purging valves, flow switches,

shut-off valves, and supply water temperature sensors. Install sensors or probes in a location that will sense supply water temperature from all modules. Follow manufacturer's instructions.

HYDROTESTING THE SYSTEM

1. Check that the flow direction arrows on all hydronic components, circulators, zone valves, check valves, pressure reducing valve, manual purging valves, air separators, etc., are facing in the proper direction.

2. Fill entire system with water and pressurize. Inspect all fittings & components for visible signs of leakage. If no pressure drop is detected for a two-hour period under pressure, system may be considered water tight.

SECTION 4: VENTING THE BOILERS

PLANNING AHEAD

WARNING: This boiler must be vented in accordance with Part 7, Venting of Equipment, of the latest edition of the National Fuel Gas code, ANSI Z223.1 and all applicable local building codes. In Canada, follow CAN/CGA B149.1 or .2 Installation Codes. Improper venting of this appliance can result in excessive levels of carbon monoxide which can result in severe personal injury or death!

VENT PIPING REQUIREMENTS

1. Each boiler is equipped with air intake and exhaust connections located at the rear of the boiler. Air intake is at top; exhaust is at bottom. Both connections are female plastic fittings designed to accept 1-1/2" pipe (AM-100), 2" pipe (AM-150) & 3" pipe (AM-300).

2. Air intake piping MUST BE Schedule 40 Poly Vinyl Chloride (PVC) pipe. Exhaust piping MUST BE Schedule 40 Chlorinated Poly Vinyl Chloride (CPVC) pipe. Note: This is a warranty requirement. Both must be vented separately, through a roof, wall or dormant chimney. Piping between boiler and outdoors must be within following permissible lengths, see Figure 4.1:

Model AM-300: Maximum of 60 running ft of 3" pipe with 6 elbows. Minimum 6 ft with 2 elbows. For natural gas only.

Model AM-150: Maximum of 40 Nat / 25 LP running ft of 2" pipe with 6 elbows; or maximum of 100 running ft where first 40 ft is 2" pipe with 5 elbows maximum followed by 60 ft of 3" pipe with 4 elbows maximum. To avoid a condensate trap, transition from 2" to 3" pipe must be made in a vertical run. Minimum 6 ft with 2 elbows. For natural gas and propane.

Model AM-100: Maximum of 25 running ft of 1-1/2" pipe with 6 elbows; or maximum of 40 running ft of 2" pipe with 6 elbows; or maximum of 100 running ft of 3" pipe with 6 elbows. Minimum 6 ft with 2 elbows. For natural gas and propane.

NOTE: Do not use piping having different diameters except where noted for the AM-150 and on the air intake termination on LP AM-100's using 3" pipe.

3. Both air intake and exhaust piping must be routed as directly as possible and must not be manifolded. All piping runs must be sloped toward the boiler with a pitch of at least 1/4" or more per foot.

CAUTION: Failure to pitch piping runs properly can result in a condensate trap which can restrict venting and result in an inoperative boiler.

4. There must be no low spots in either piping run. A high spot is acceptable in either piping run, provided the pitch from the high spot is maintained back to the boiler and to the outside point of air intake or exhaust.

5. Avoid rigid connections between piping and structural members of building. Piping must be supported with vibration isolating hangers to prevent transmission of vibrations into structure. To avoid possible sagging on horizontal runs that can result in condensate traps, maximum spacing between the piping supports must not exceed 7-feet for air intake and 5-feet for exhaust. For long horizontal runs, continuous support, closer spacing of supports or increased pitch of piping runs should be used to avoid condensate traps that could occur.

PLANNING AHEAD (continued)

VENT PIPING AND MUFFLERS							VENT TERMINATION				
							THROUGH THE WALL			DORMANT CHIMNEY & THRU ROOF (4)	
Boiler Model	Type of Vent	Pipe size (1)	Trans. at Boiler (2)	Max. Running Feet of Pipe (3)	Max. No. of Elbows (3)	Muffler Size	Air Intake Pipe (2)	Vent Terminal Plate		12" Exhaust Extension	Air Intake 180° Ell (2)
								Size	Coupling		
AM-100	Exhaust	1 1/2"	---	25	6	1-1/2" x 41"	---	1-1/2"	---	1-1/2"	---
	Air Intake	1 1/2"	---	25	6	1-1/2" x 22"	3 x 36	3"	3" x 1-1/2"	---	1-1/2"
AM-100	Exhaust	2"	2" x 1-1/2"	40	6	2" x 41"	---	3"	---	2"	---
	Air Intake	2"	2" x 1-1/2"	40	6	2" x 24"	3 x 36	3"	3" x 2"	---	2"
AM-100	Exhaust	3"	3" x 1-1/2"	100	6	3" x 41"	---	3"	---	3"	---
	Air Intake	3"	3" x 1-1/2"	100	6	3" x 41"	3 x 36	3"	---(5)	---	3"(5)
AM-150	Exhaust	2"	---	40	6	2" x 41"	---	3"	---	2"	---
	Air Intake	2"	---	40	6	2" x 22-1/2"	3 x 36	3"	3" x 2"	---	2"
AM-150	Exhaust	2" + 3"	---	40(2") + 60(3")	5(2") + 4(3")	2" x 41"	---	3"	---	3"	---
	Air Intake	2" + 3"	---	40(2") + 60(3")	5(2") + 4(3")	2" x 22-1/2"	---	3"	---	---	3"
AM-300	Exhaust	3"	---	60	6	3" x 41"	---	3"	---	3"	---
	Air Intake	3"	---	60	6	3" x 41"	---	3"	---	---	3"

(1) Mixing of pipe sizes during run is not allowed, except for AM-150 as shown. (2) Field-supplied materials. (3) Minimum of 6 running feet with 2 elbows. (4) For dormant chimney and through-the-roof installations, exhaust pipe termination must be 12" longer than the air supply termination. (5) For Propane Only - Use 3" x 1½" reducer coupling on intake termination.

6. At transitions from horizontal to vertical piping, sufficient support must be provided to prevent sagging at end of horizontal runs and to support weight of vertical riser.

7. Avoid routing vent piping internally through walls, ceilings, in close proximity to any exposed ductwork, or under any sleeping areas.

8. Always allow sufficient access to the vent piping for annual inspection.

9. Carefully prepare and cement all pipe and elbows together including boiler connections. Use proper solvent cementing techniques. Remove all burrs and shavings from the ends of cut pipe prior to cementing.

NOTE: Improperly cleaned/de-burred joints may result in pipe shavings/burrs being carried back to boiler by condensate; this will result in clogged condensate drain fittings.

VENT TERMINATION REQUIREMENTS

1. In U.S., vent terminations must meet the following requirements: Minimum clearance of 4-ft horizontally from nearby electric meters, gas meters, regulators and relief equipment; minimum of 12" from any opening through which flue gases could enter the building; minimum of 3-ft above a forced air inlet located within 10-ft; minimum of 12" above grade and normal snow line to bottom of terminal or minimum of 7-ft above grade if

venting adjacent to public walkway.

2. In Canada, vent termination must meet the following requirements: Minimum of 6-ft from a combustion air inlet of another appliance; minimum of 3-ft from any other building opening or any gas service regulator; not directly above a gas utility meter or service regulator; minimum of 12" above grade and normal snow line to bottom of terminal or minimum of 7-ft above grade if venting adjacent to public walkway.

3. When selecting a vent terminal location, consideration must be given for the sound and vapor which will be present at the termination point. Due to the condensing vapor, avoid terminating where slightly acidic moisture and/or frost can damage building materials. Be advised that some discoloration of the outside wall can occur, due to the condensing vapor.

4. Avoid vent terminal locations near sources of contaminated air such as building exhaust vents, equipment vents, air conditioning and refrigeration equipment. Avoid locating boiler exhaust terminations near building ventilation air intakes.

5. To prevent slippery conditions, or where the presence of condensate from exhaust outlet will be objectionable, avoid venting over any sidewalk, driveway or mechanical equipment.

PLANNING AHEAD (continued)

6. To maintain outdoor sound at a minimum and assure a free open area where exhaust gases can be properly dispersed, avoid venting into narrow alleyways or alcoves, at neighboring windows, in any window well or near bedroom windows. In other venting situations, where outdoor sound may be objectionable, mufflers must be installed to reduce sound.

7. For through-the-wall or through-the-roof installations, air intake and exhaust terminations must be separated from 18" minimum to 8-ft maximum ON THE SAME WALL OR ROOF.

VENTILATION CONSIDERATIONS

Pulse boilers may be installed within a closed room; however, for modular installations, we recommend providing some means of boiler room ventilation to control temperature. This can normally be provided by louvered openings in boiler room walls to the outdoors. Check local codes for additional requirements. Building ventilation systems should never have air intakes or return air ducts located within a boiler room.

DORMANT CHIMNEY INSTALLATION

1. When running piping up through an existing chimney, be sure chimney and flue are dormant; that is, not connected to a fireplace, water heater or any other heating appliance. In Canada, the exhaust vent shall not be run through interior part of an open chimney unless the exhaust vent is insulated.

2. Air intake pipe termination must be as shown in Figure 4.2, with a 180° ell (return bend) installed on air intake pipe.

3. Exhaust pipe termination must be 12" longer than air intake pipe to prevent exhaust recirculation.

For 3" piping on propane AM-100, cement a reducer coupling and short tubing transition to the inlet termination only, see Figure 4.2.

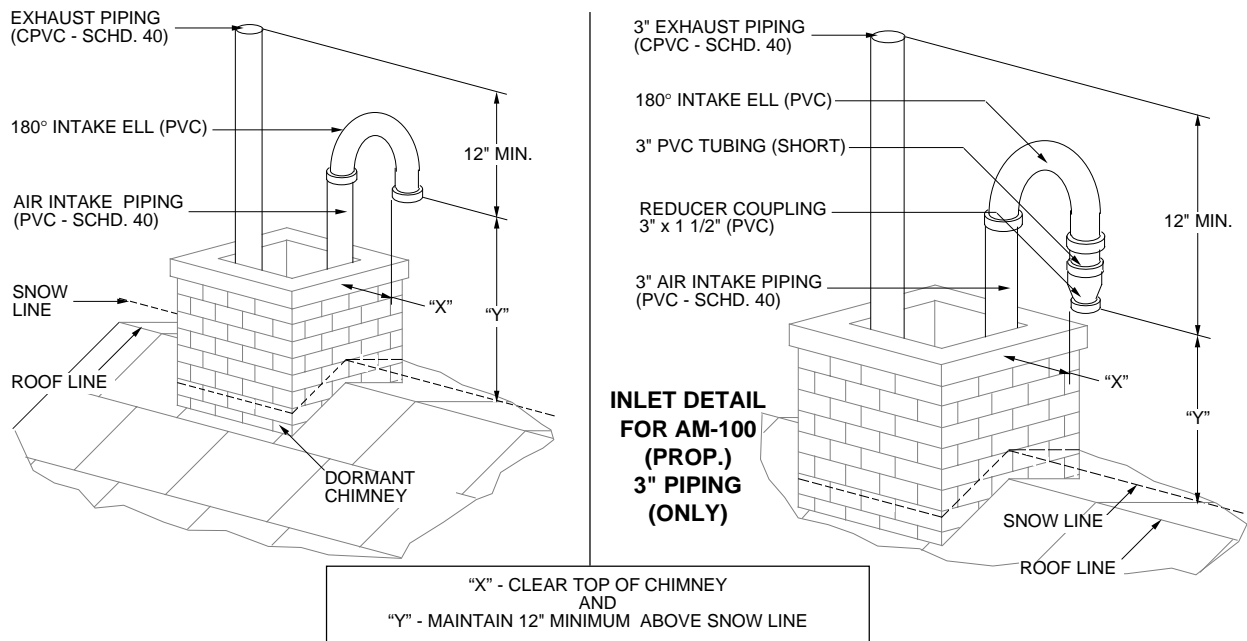

FIGURE 4.2

THROUGH-THE-ROOF INSTALLATIONS

Each air intake pipe must have a 180° ell installed. Each exhaust pipe termination must be 12" longer than air intake, see Figure 4.3. For 3" piping on Propane AM-100, cement a reducer coupling and short tubing

transition to the inlet termination only. Refer to Figure 4.3 and for additional clearance information, Figures 4.4, 4.5, and 4.6.

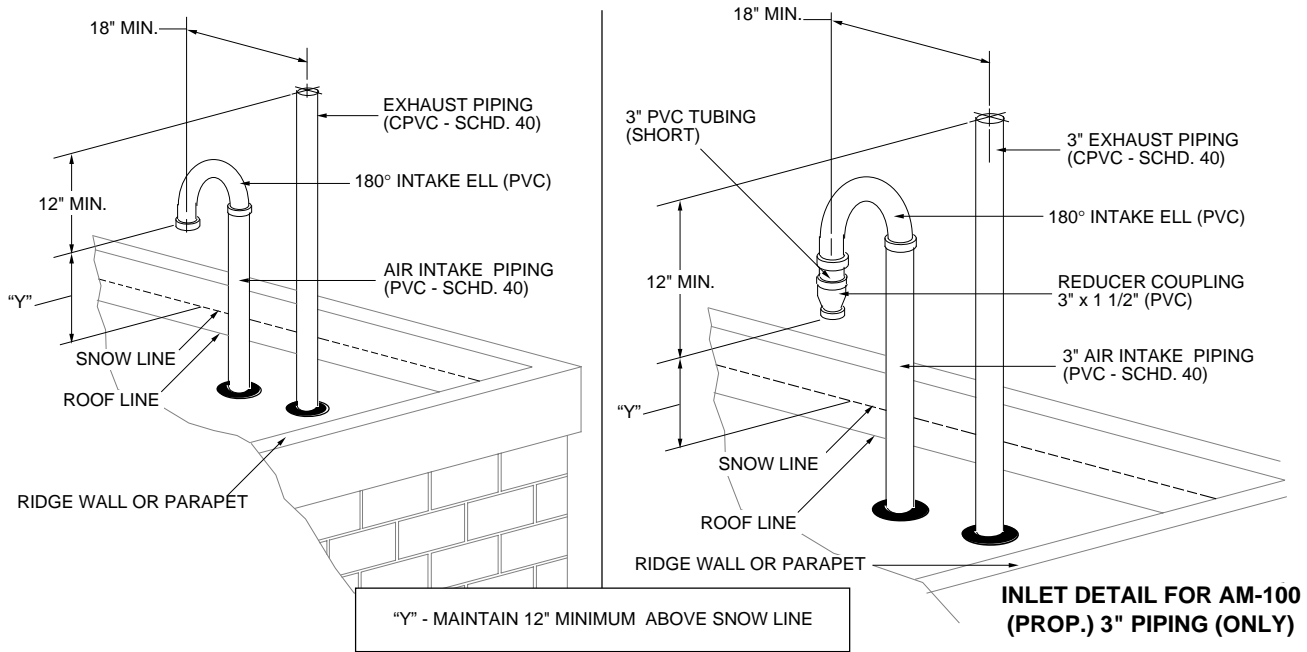

FIGURE 4.3

MULTIPLE UNIT INSTALLATIONS

PREFERRED METHOD

As shown in Figure 4.4, each set of air intake and exhaust terminations must be separated 18" minimum from the next set; each air intake and exhaust termination within a set must be separated 18" minimum.

For 3" piping on Propane AM-100, cement a reducer coupling and short tubing transition to the inlet termination only as shown in Figure 4.3.

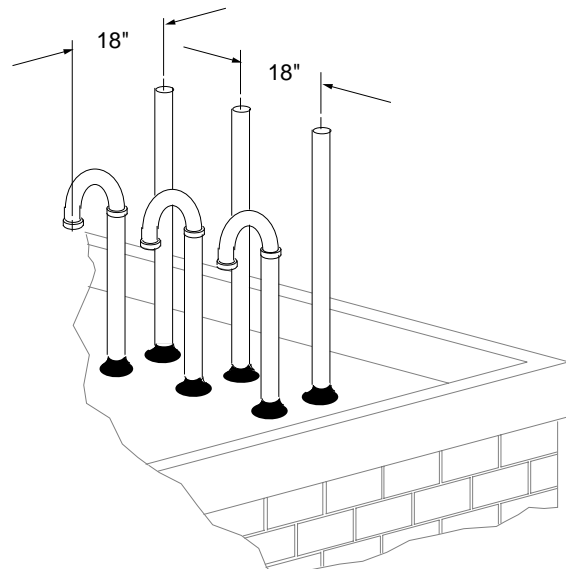

FIGURE 4.4

MULTIPLE UNIT INSTALLATIONS (continued)

ALTERNATE ARRANGEMENT

As an alternate, air intake & exhaust terminations may be arranged in clusters, as shown in Figure 4.5. The possibility of exhaust gas recirculation is greater with this arrangement; therefore, it is very important that the exhaust cluster be located downwind of the air intake cluster. Clearances to roof must be as shown in

Figure 4.6. Separation distance between clusters should be as large as practical within limits shown in Figure 4.5.

Each air intake pipe must have a 180° ell installed. Each exhaust pipe termination must be 12" longer than air intake.

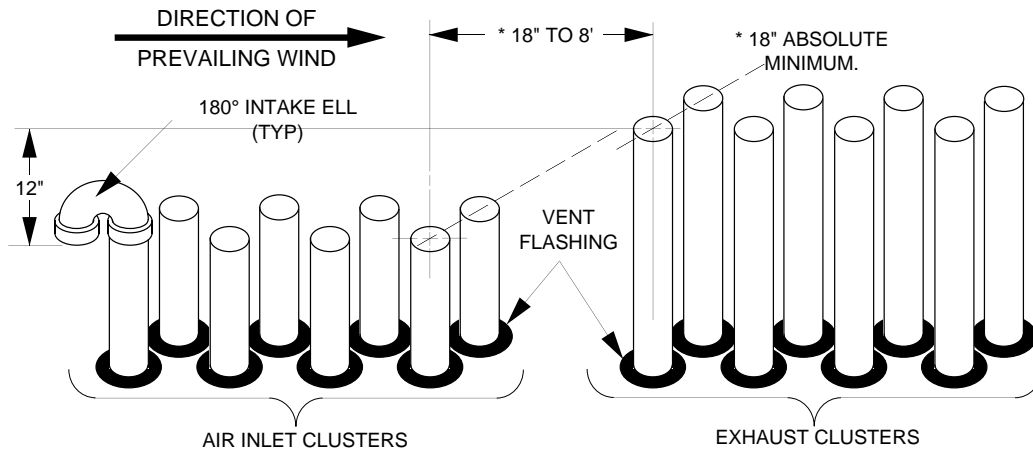

FIGURE 4.5

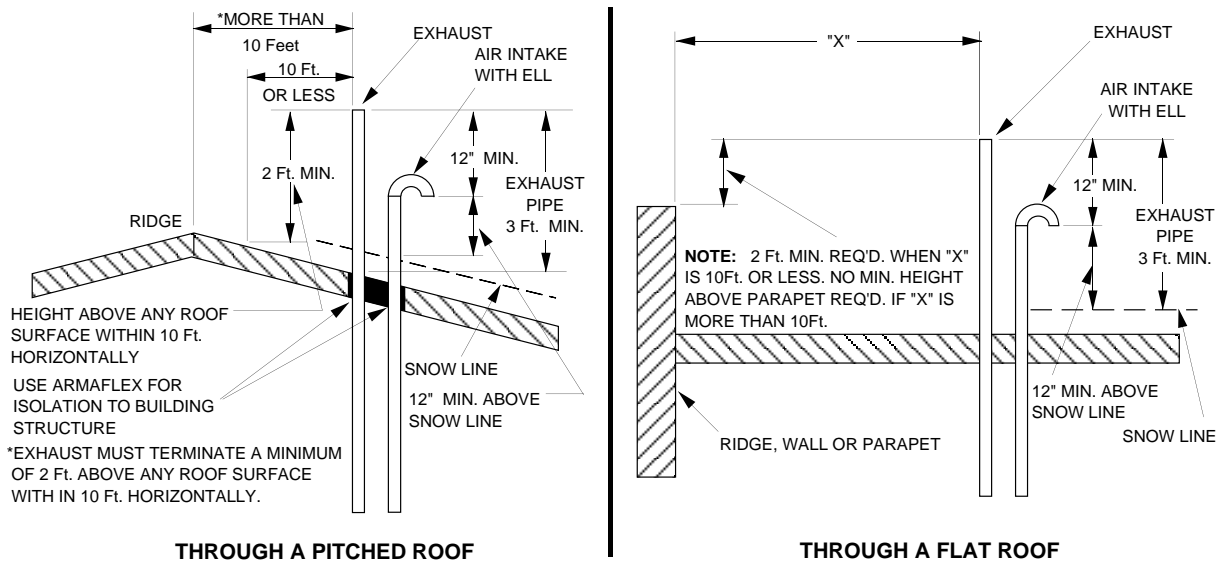

FIGURE 4.6

THROUGH-THE-WALL INSTALLATIONS

Multiple air intakes and exhaust outlets can be arranged either in-line or in clusters as shown in Figure 4.6. Again, the possibility of exhaust recirculation is greater with a cluster arrangement. Exhaust clusters must be located downwind of air intake clusters and separation distance between the two clusters should be as large as practical within limits specified in Figure 4.7. There is no minimum

distance required between individual air intake vent terminals or between individual exhaust vent terminals. If mufflers are required, follow installation instructions packaged with the muffler sets.

See **“Single Unit Installations”** for additional venting requirements.

* NO MINIMUM DIMENSION BETWEEN EXHAUST OUTLETS OR BETWEEN AIR INTAKES

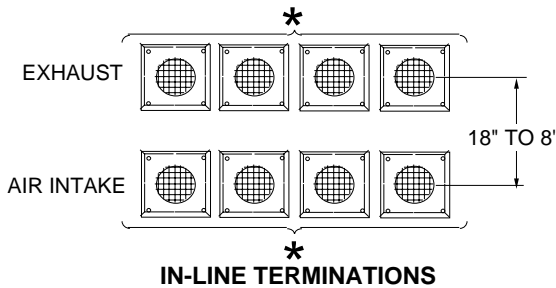

DIRECTION OF PREVAILING WINDS

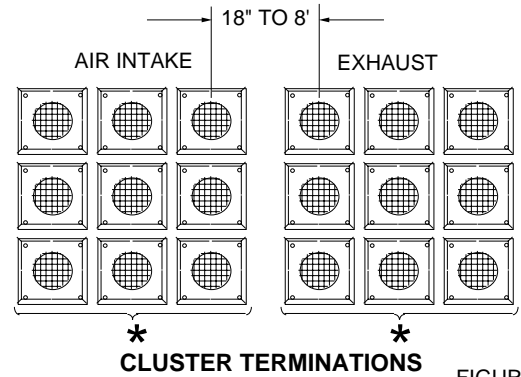

FIGURE 4.7

FOR SINGLE UNIT INSTALLATIONS

For single unit installations, air intake and exhaust terminations should be separated by 18" minimum. Exhaust terminal must be located above inlet to prevent recirculation of combustion products and must be on the same wall. Exhaust terminal must extend 12" beyond wall. Protect all terminations from vermin, etc. with terminal plates.

For 3" piping on Propane AM-100, cement a reducer coupling and short tubing transition to the inlet termination only as detailed in Figure 4.8A.

FOR INSTALLATIONS USING 2" & UNDER PIPE

For exhaust, install vent pipe, plus vent terminal plate, plus 12" exhaust extension. For air intake, install vent pipe to within 36" of outside wall, add approximately-sized reducer coupling, complete run with 3" x 36" air intake pipe, and install vent terminal plate, see Figure 4.9.

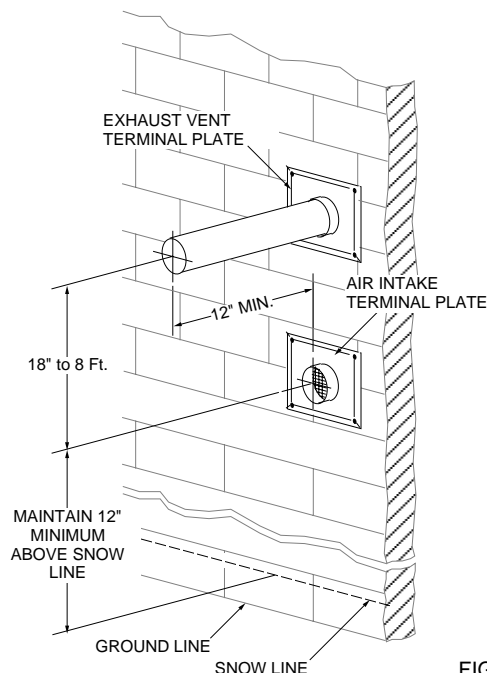

FIGURE 4.8

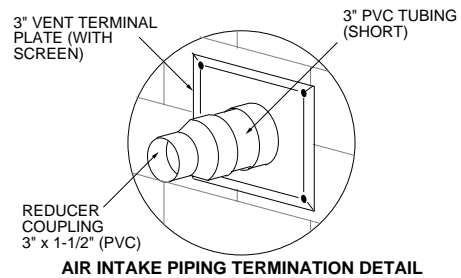
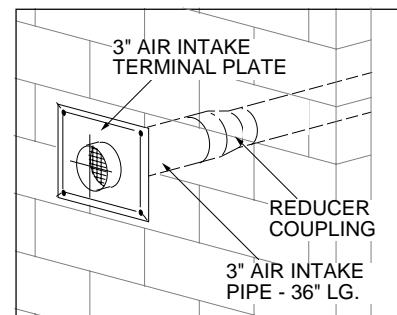

FIGURE 4.8A



AIR INTAKE PIPING FOR INSTALLATIONS USING

FIGURE 4.9

SECTION 5: INSTALLING CONDENSATE LINE

It is recommended that the condensate system be sealed and vented to the outdoors to prevent objectionable odors in the mechanical room, Figure 5.2. The condensate pipe must be as short as possible and pitched downward away from the boilers.

Standard Size Condensate Line Without a "P" Trap

Condensate lines made from 3/8" ID, for AM-300, or 1/4" ID, for AM-100 and 150, rubber hose or plastic tubing can be manifolded from each boiler into a common condensate pipe which runs into a floor drain or to a condensate receiver tank or pump, Figure 5.1.

Standard Size Condensate Line With a "P" Trap

The boilers must be installed on a solid pedestal that raises them at least 5" above the floor before a "P" trap can be installed. Condensate lines made from 3/8" ID, for AM-300, or 1/4" ID, for AM-100 and 150, rubber hose or

plastic tubing having a 4" "P" trap, Figure 5.3, can be manifolded from each boiler into a common condensate pipe which runs into a floor drain or to a condensate receiver tank or pump, Figure 5.1.

Oversized Condensate Line With a "P" Trap

The boilers must be installed on a solid pedestal that raises them at least 7" above the floor before oversized condensate lines with "P" traps can be installed. Install the oversized condensate lines with "P" traps as shown in Figure 5.4. Condensate lines from each boiler can be manifolded into a common condensate pipe which runs into a floor drain or to a condensate receiver tank or pump, Figure 5.1.

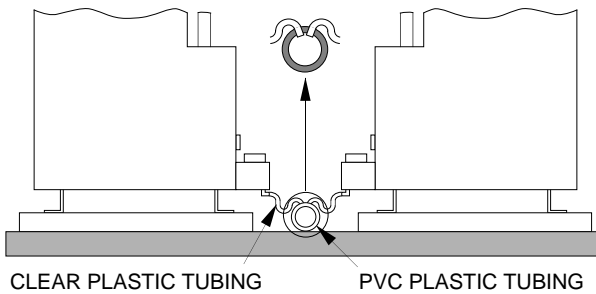

FIGURE 5.1

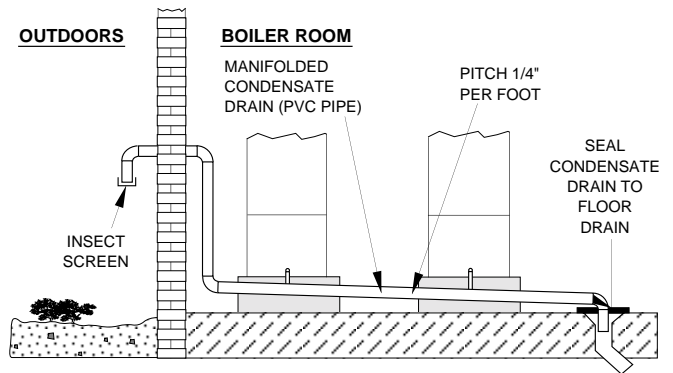

FIGURE 5.2

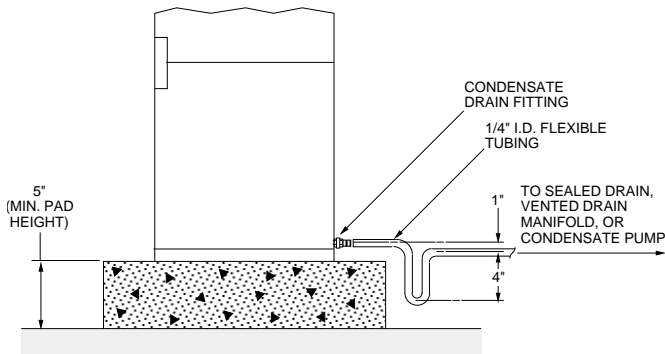

FIGURE 5.3

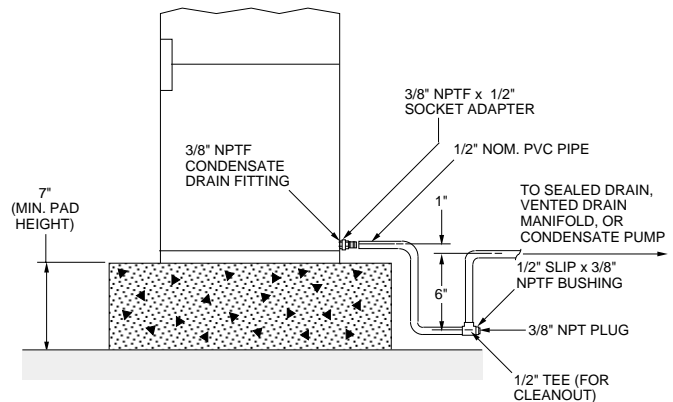

FIGURE 5.4

SECTION 6: INSTALLING GAS PIPING

CONNECTING PIPING

Gas main and gas headers must be sized to provide a maximum pressure drop of 0.3" W.C. for natural gas or 0.5" W.C. for propane between the gas meter and each module's gas valve. If shop drawings are not available, use sizing guidelines recommended in Appendix A of this manual.

Gas header is the manifold to which each module's gas valve is connected. If total equivalent pipe length, straight pipe + fittings, from gas valve inlet to header is 5-feet or less, use a pipe diameter that matches gas valve inlet; over 5-feet, calculate pipe diameter.

Connect gas piping from meter following good piping practices. Pipe joint compound must be compatible with natural and propane gas being used. Check local codes/ utilities for any special requirements. All piping must be supported by hangers, not by boiler or its accessories.

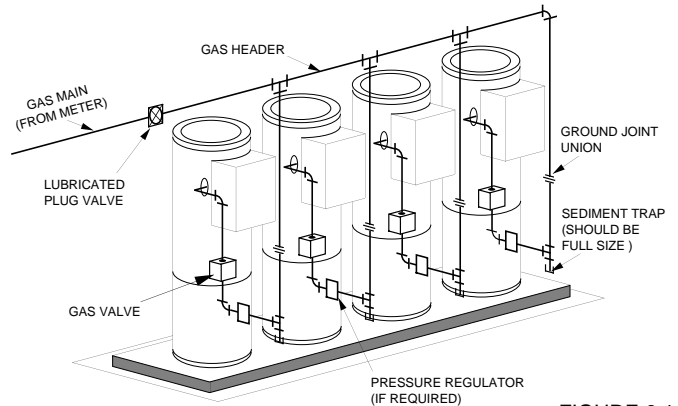

FIGURE 6.1

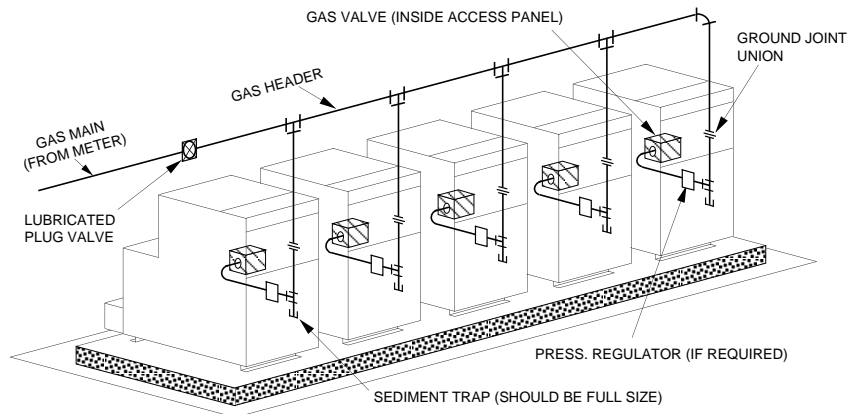

FIGURE 6.2

TESTING GAS PIPING

DANGER: Before placing gas piping into service, carefully test it to assure every joint is gas tight. Bubble test all joints with a soap solution. NEVER TEST WITH AN OPEN FLAME AS FIRE OR EXPLOSION WILL RESULT.

For any pressure testing in excess of 1/2 psi, the boiler and its individual shutoff valve must be isolated from the piping system by disconnecting them and capping the outlet(s). For any pressure testing equal to or less than 1/2 psi, the boiler must be isolated from the piping system by closing its manual shutoff valve.

Static and operating pressure required at gas valve inlet is between 4.5" and 7" W.C. for natural gas and 11" W.C. for propane. If gas pressure is above this limit, a pressure regulator must be installed, which must be a lock-up style to prevent pressure variations when boiler is not operating, see Figure 6.3. If gas pressure is below these limits, contact local utility.

For propane boilers, if reading exceeds or is less than 11" W.C., adjust regulator on propane tank or at entrance to the residence.

Boiler Model	LOCK-UP STYLE GAS REGULATORS			
	Natural Gas Supply Pressure		Propane Gas Supply Pressure	
	8"-11"W.C.	11"-14"W.C.	+14"W.C.	+11"W.C.
AM-100	325-5 *RV-48	325-3 325-5	325-3 325-5	325-3 325-5
AM-150	R600S	325-5	325-5	N/A
AM-300	*R600S	*R600S	325-5	N/A

NOTE: Maxitrol models are shown. Other brand names with equivalent models are available.

FIGURE 6.3

SECTION 7: WIRING THE BOILERS

DANGER: Turn off electrical power supply before servicing. Contact with live electric components can cause shock or death.

CAUTION: Label all wires prior to disconnection when servicing controls. Wiring errors can cause improper and dangerous operation! Verify proper operation after servicing.

NOTE: If any original wire supplied with the boiler must be replaced, use similar wire of 105 C rating. Otherwise, insulation may melt or degrade, exposing bare wire.

NOTE: Boiler transformer(s) must not be used to power external accessories such as zone valves, relays, etc. Otherwise, transformer(s) will be overloaded and burn out.

All electrical wiring must be in accordance with the requirements of authority having jurisdiction or, in absence of such requirements, with National Electric Code NFPA -70-latest edition and any additional state or local code requirements. If an external source is utilized, installed boiler must be electrically grounded in accordance with the requirements of authority having jurisdiction or, in

absence of such requirements, with National Electric Code NFPA -70-latest edition. UL listed power limited circuit cable is almost universally approved for safety controls on heating equipment, either internally or externally, without protection of conduits or raceway

For Canada, all electrical connections are to be made in accordance with Standard C.S.A. C22.1 Canadian Electrical Code, Part 1 and Part 2, and/or local codes.

If shop drawings with approved control selection and wiring diagrams are not available, you can use the control and wiring guidelines recommended in Appendix B of this manual.

Safety devices such as low water cut-offs and manual reset hi-limits must be wired so they shut down all boilers protected by those devices. Switch ratings on safety or control devices must not be exceeded; this may require the use of relays for larger heating plants.

Air and water temperature sensor wiring must not be run in the same conduit as power wiring; use shielded wiring in runs over 25 feet long.

Power requirements per boiler are 1.5 amps 115v/60Hz.

WARNING: DO NOT ATTEMPT TO START BOILER(S), NOT EVEN MOMENTARILY, TO TEST WIRING BEFORE FILLING AND PURGING BOILER(S)! DAMAGE CAUSED BY A DRY-FIRE IS NOT COVERED BY WARRANTY.

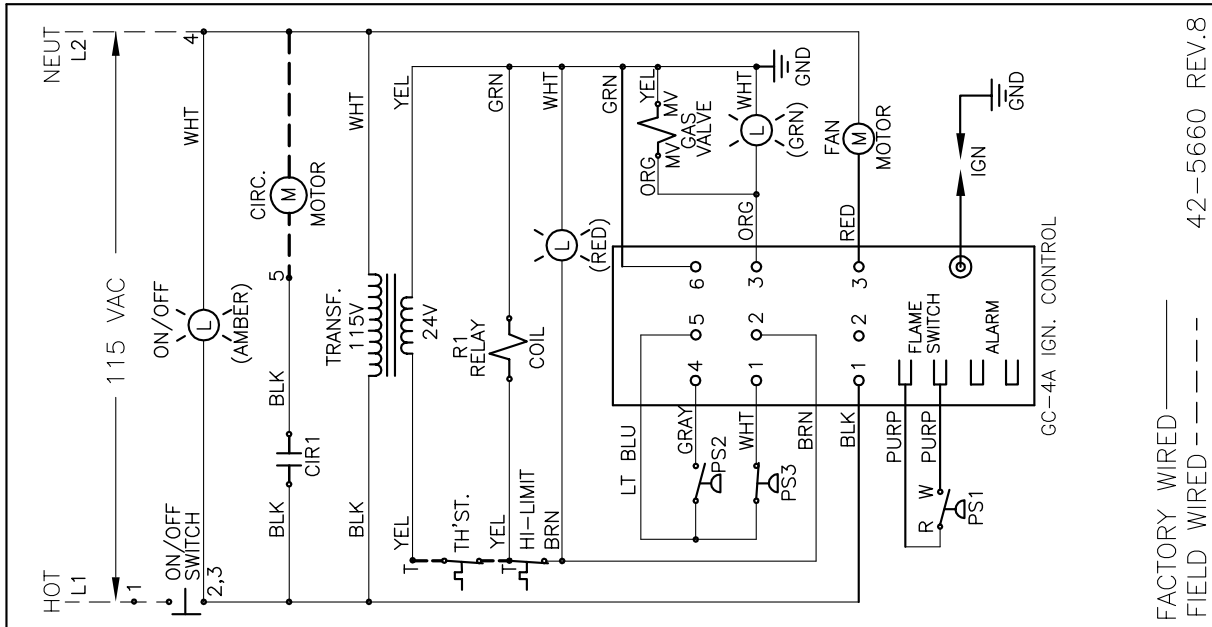

FACTORY WIRED _____
 FIELD WIRED ----- 42-5660 REV.8

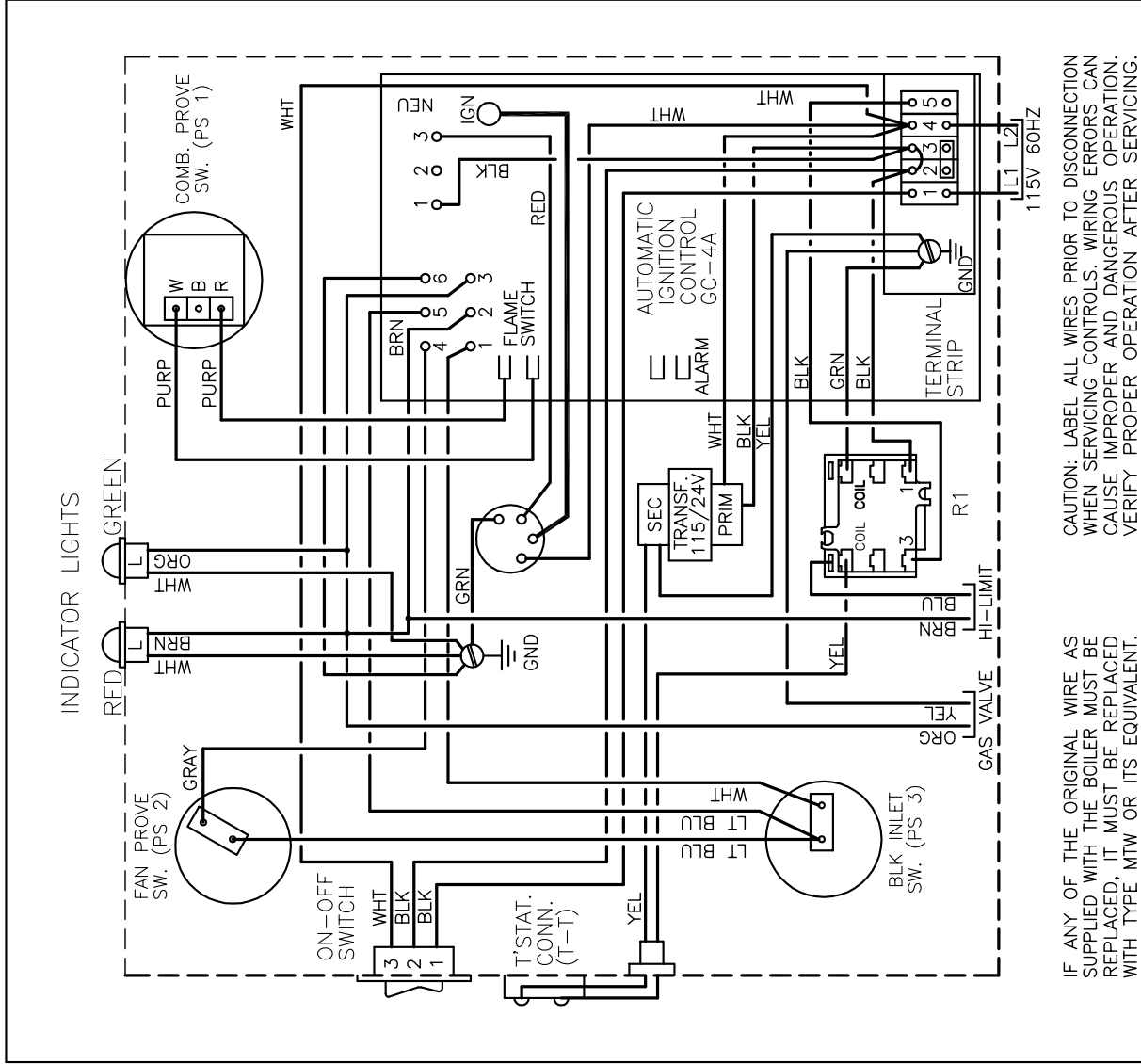

CAUTION: LABEL ALL WIRES PRIOR TO DISCONNECTION WHEN SERVICING CONTROLS; WIRING ERRORS CAN CAUSE IMPROPER AND DANGEROUS OPERATION. VERIFY PROPER OPERATION AFTER SERVICING.

IF ANY OF THE ORIGINAL WIRE AS SUPPLIED WITH THE BOILER MUST BE REPLACED, IT MUST BE REPLACED WITH TYPE MTW OR ITS EQUIVALENT.

FIGURE 7.2: WIRING DIAGRAM FOR MODEL AM-150

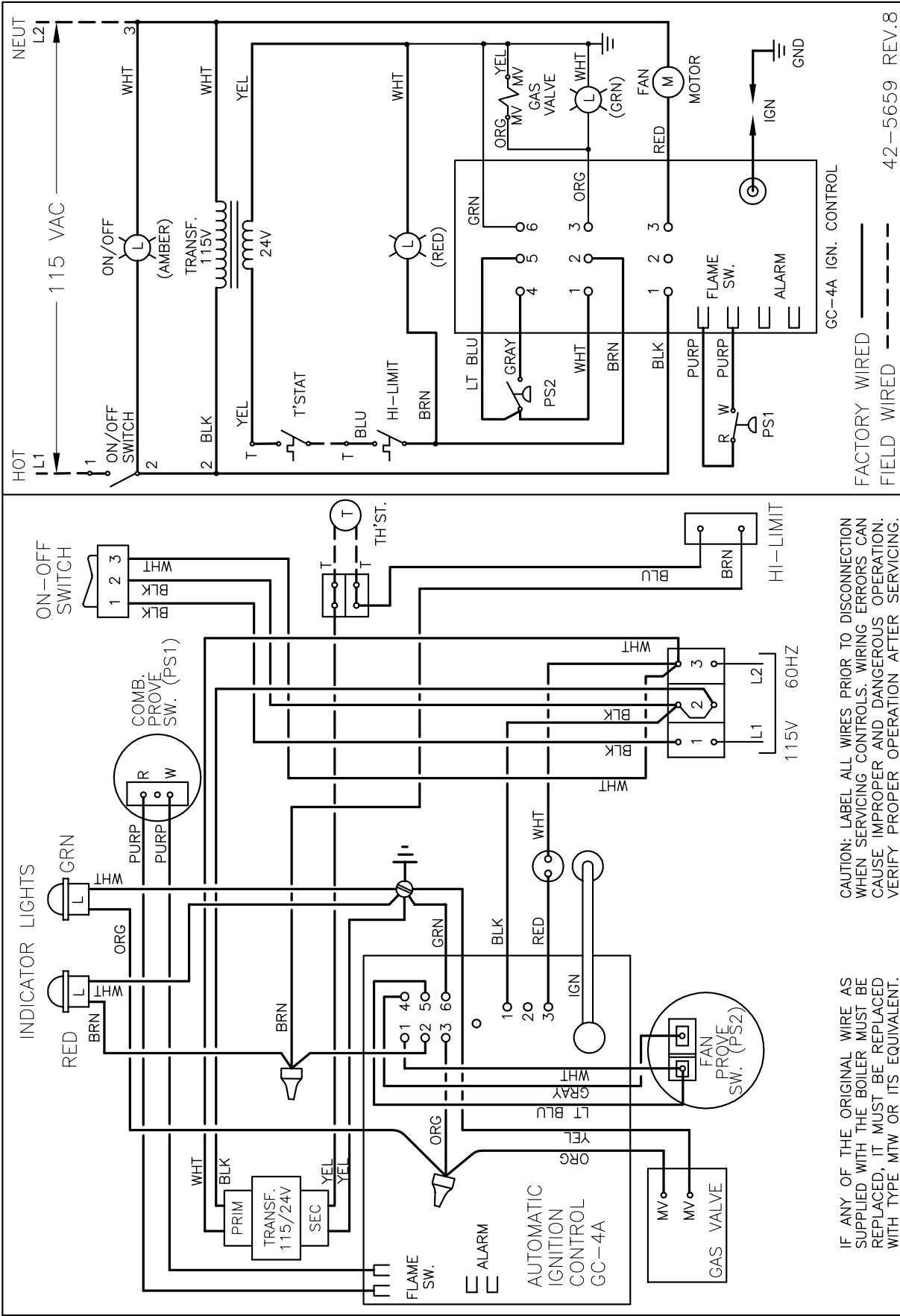

FIGURE 7.3: WIRING DIAGRAM FOR MODEL AM-300

SECTION 8: START-UP & OPERATION

WARNING: DO NOT ATTEMPT TO START BOILER(S), NOT EVEN MOMENTARILY, BEFORE FILLING AND PURGING BOILER(S)! DAMAGE CAUSED BY A DRY-FIRE IS NOT COVERED BY WARRANTY!

SEQUENCE OF OPERATION

1. Line switch SW1 is closed, powering 115/24v transformer. Switch light is ON.

2. Thermostat or operating control calls for heat, closes, making T-T contacts.

3. 24 volts is also supplied to high limit. If limit is open, GC-4A control waits. When or if limit is closed, **(red indicator light comes on and green light is off)**, GC-4A control is energized and checks position of combustion prove switch PS1 and lockout switch PS3 on AM-150. If switch PS1 is closed and/or switch PS3 on AM-150 is open, GC-4A control will go on standby.

When or if switch PS1 is open and switch PS3 on AM-150 is closed, GC-4A control will begin ignition sequence and fan will start.

4. After approximately 35 seconds, GC-4A control will check position of fan prove switch PS2. If switch PS2 is open, fan will continue to run but there will be no attempt at ignition. If switch PS2 remains open, fan will run for 3-1/2 minutes, after which GC-4A control will go into a 15-minute wait mode, after which GC-4A control will again initiate attempt for ignition. If switch PS2 remains open, the attempt at ignition cycle will occur a total of 13 times at 15-minute intervals, after which GC-4A control will go into a lockout mode requiring a line voltage or thermostat reset.

When or if switch PS2 is closed, GC-4A control will provide a high voltage spark and open gas valve for an 8-second trial for ignition **(red indicator light on; green light comes on)**.

5. Trial For Ignition: If ignition occurs during 8-second trial, the combustion chamber pressure is sensed by pressure switch PS1, closing contacts R-W and completing sensing circuit. Fan prove switch PS2 now

opens; however, gas valve remains energized through internal circuitry of GC-4A control. Fan and ignitor circuit will be de-energized when contacts R-W close. All timer circuits will be reset at the end of the heating call. **The red and green indicator lights remain on.**

If ignition does not occur during 8-second trial, spark and gas valve will shut off **(red indicator light on; green light shuts off)** but fan will continue to run. After 26 seconds, GC-4A control will check fan prove switch PS2 position. If closed, GC-4A control will initiate another 8-second trial for ignition. This sequence of 26 seconds off, 8 seconds on will occur three more times, after which gas valve, high tension spark and fan will be de-energized until the 15-minute wait mode ends. The attempt at ignition cycle will occur a total of 13 times at 15-minute intervals, after which GC-4A control will go into a lockout mode requiring a line voltage or thermostat reset.

6. During Run Mode: If water temperature exceeds high limit setting, limit will open and boiler will shut down **(red and green indicator lights will shut off)**. After water temperature drops below limit set point, GC-4A control will restart ignition sequence, see Step 3.

For AM-150 Boilers Only: During run mode, if air inlet pressure in air cushion chamber drops below pressure switch PS3 setting, switch PS3 will open interrupting the internal circuitry of the blocked flue circuit in the control. At this time, the gas valve will close **(red indicator light on; green light shuts off)** and the unit will go into a 15-minute wait mode, after which the GC-4A control will initiate an attempt for ignition sequence.

7. When thermostat or operating control is satisfied, its contacts open, shutting off gas valve **(red and green indicator lights shut off)**. All circuits will be reset awaiting another call for heat.

NOTE: Refer to GC-4A Ignition Control Troubleshooting Guide, Part I, Section 9, In This Manual.

PURGING & START-UP PROCEDURES

DANGER: To avoid fire or explosion hazards, do not store anything against the boiler or allow dirt or debris to accumulate in the area immediately surrounding the boiler. Keep boiler area clear and free from combustible materials, gasoline and other flammable vapors and liquids. Lint, paper or rags must not be allowed to accumulate near the burners. Do not place clothing on boiler casing to dry.

1. Make sure boiler combination gas valves are OFF.
2. If system was not previously hydrotested, fill system and boilers with water and thoroughly purge at high pressure, overriding system pressure reducing (fill) valve pressure setting.
3. Check air elimination equipment for proper operation to be certain there is no air in the water system.
4. **With gas shut-off valve closed**, turn on power to all modules. Open all zones individually and let system circulator(s) run until all air is purged from each piping loop. Then operate system circulator(s) with all zones open to ensure complete purging.
5. When purging is complete, reset pressure reducing (fill) valve back to desired operating pressure.
6. Check the supply and return water connections on each module and its headers for leaks.

7. Check all safety and operating controls to be sure they are operating in accordance with manufacturer's recommendations. Ensure that low water cutoffs and manual reset high limits actually shut down the heating plant as intended.

8. Check for proper high limit control settings on each module. Set high limit to 220°F and differential at 20°F.

9. Open gas shut-off valve, allowing gas to flow to boilers.

10. With electrical supply to heating plant energized, set controls to call for heat and light boiler modules. Follow directions in lighting instruction labels on module jackets. Safe lighting and other performance criteria were met with the gas manifold and control assembly provided on the boiler when the boiler underwent tests specified in ANSI Z21.13-latest edition.

11. Allow system to heat up to approximately 120°F operating temperature. Shut off gas supply to modules and allow circulator to circulate system water through all loops and zones. Repeat this procedure for each 20°F rise in operating temperature until final design operating temperature is attained. This will allow air, released from water when it's heated, to escape by means of air separation and elimination components.

OPERATION ADJUSTMENTS

HIGH ALTITUDE INSTALLATIONS

A reduction of appliance input must be made to account for the effects altitude has on available air supply for the units installed in areas exceeding 2,000 ft. elevations. This derate also affects the boiler output and flow rate specifications accordingly.

Gas input reduction only is required for elevations greater than 2,000 ft. It is to be made by reducing the pressure regulator setting (ccw rotation) of the gas valve in accordance with the procedure outlined under "Operation Adjustments" of this manual.

The boiler is factory adjusted for the respective gas at the normal or "sea-level" input marked on the rating label. Refer to the instruction manual and adjustment label inside control box, before making any input pressure adjustments.

All pressure adjustments should be made with the boiler "OFF." All pressure readings should be measured with the boiler running and the gas valve regulator cap securely in place.

U.S. Installations

Use ANSI Z223.1 recommendation. For operation at altitudes above 2,000 ft. derate rating label input and resulting ratings by 4% for each 1,000 ft above sea-level.

Canada Installations

Use CAN/CGA 2.17 recommendation. For operation at altitudes between 2,000 ft. and 4,500 ft. – reduce appliance input 10% to the value shown on rating label for HIGH-ALTITUDE installations.

After completing the Canada input reductions - mark the "derate completion" box on the rating label on the appliance.

CHECK GAS INPUT RATE

After heating plant has been in operation for about 10 minutes, check gas input rate to each module using one of the two following methods:

Method #1: Measure Gas Flow Input, Natural Gas Only

Make sure all other appliances served by the gas meter are turned off during timing of gas input rate. Before calculating the input of the heating equipment, obtain heating value of the gas from the local utility.

At meter, with stopwatch, measure time in seconds it takes for the boiler to use 10 cubic feet of gas. Divide 36,000 by number of seconds. This is the number of cubic feet of gas used per hour. Multiply this figure by heating value of the gas to obtain Btu input per hour.

Example: An AM-300 boiler takes 120 seconds to use 10 cubic feet of natural gas. The local utility indicated the heating value of the natural gas being supplied is 1000 Btu/cu ft. Therefore:

$$\frac{36,000 \times 1000}{120} = 300,000 \text{ Btu/hr.}$$

Boiler input within 2% of nameplate is correct.

Method # 2: Measure Differential Pressure

Turn off boiler & combination gas valve. It is not necessary to turn off other gas appliances served by same gas meter.

Remove plug from pressure tap in the gas line downstream from combination gas valve. Replace plug with a 1/8 NPT to 3/16" barb or flare compression adapter. Connect a piece of 3/16" tubing from adapter to either side of a manometer.

Remove downstream manifold pressure test plug from combination gas valve. Replace plug with a 1/8 NPT to 3/16" barb or flare compression adapter. Connect a second piece of 3/16" tubing from adapter to open side of manometer.

Open gas valve and turn on boiler. Remember to add the two manometer water columns together to get reading. After combustion starts, manometer should read as follows:

AM-100: 2.8" W.C. Natural Gas; 4.5" W.C. LP Gas

AM-150: 2.1" W.C. Natural Gas; 6.8" W.C. LP Gas

AM-300: 1.6" W.C. Natural Gas

Refer to "High Altitude" section for exceptions.

If boiler input needs to be corrected, turn off boiler, remove cap on combination gas valve pressure regulator screw, and adjust regulator. Regulator is factory set for normal altitude according to differential pressure above. Turn adjusting screw clockwise to increase gas flow (increase input); counterclockwise to decrease gas flow (decrease input). Replace cap on adjusting screw, tighten securely and turn on boiler. In no case should final differential pressure setting vary more than ± 0.2 " W.C. for Model AM-300 or ± 0.3 " W.C. for Models AM-100 & 150 from factory-set pressures unless an additional altitude adjustment is required. If rated input cannot be obtained with regulator adjustment, gas supply pressure may be the cause. Consult local utility.

IN SUSPECTED HIGH GAS PRESSURE AREAS

It's good practice to check line pressure with a manometer. Turn off boiler and gas supply to gas valve.

Remove supply pressure test plug on combination gas valve. Replace plug with a 1/8 NPT to 3/16" barb or flare compression adapter. Connect a piece of tubing from the adapter to either side of manometer.

Open gas supply to combination gas valve and record supply pressure.

Turn on boiler. After combustion starts, manometer should read 4.5" to 7.0" W.C for natural gas or 11" W. C. for propane. Remember, add the two manometer water columns together to get reading.

If the two readings vary by more than 2.0" W.C., gas piping needs to be reviewed for proper size and for restrictions to flow.

For natural gas boilers, if reading exceeds 7.0" W.C., install regulator upstream of gas valve to reduce street pressure. If reading is less than 4.5" W.C., contact local utility for recent line pressure reductions.

For propane boilers, if reading exceeds or is less than 11" W.C., adjust regulator on propane tank or at entrance to the residence.

CHECK OPERATION OF CONTROLS

Start and stop boilers several times by raising and lowering the control settings.

After boilers have been firing long enough to raise boiler water temperature above minimum setting of high limit, check each boiler's high limit by turning its setting from the maximum to minimum. This should turn the boiler off. Return each high limit to desired setting.

Check ignition safety circuit on each boiler. With boiler firing, remove one of the purple sensor leads from the solid state control or from pressure switch PS1, high voltage. The gas valve should close and boiler should cease operation. Turn power off and reconnect the lead.

WARNING: High Voltage is present in control box. Avoid touching exposed wire connections or electrical shock will result.

NOTE: Do not draw water from heating system for cleaning. Minerals in the water can build up on heat transfer surfaces and cause overheating and subsequent failure of the heat exchanger.

NOTE: If system is equipped with a low water cut-off, follow manufacturer's maintenance instructions.

SECTION 9: TROUBLESHOOTING

CAUTION: Label all wires prior to disconnection when servicing controls. Wiring errors can cause improper and dangerous operation. Verify proper operation after servicing.

GC-4A IGNITION CONTROL

If boiler is having operational difficulties, and you suspect the GC-4A ignition control is defective, follow these troubleshooting procedures first, **BEFORE REPLACING THE CONTROL**. A green light, located on the GC-4A control, is visible through a hole in the

detent on the control cover. If line voltage to boiler is off or if there is no call for heat or if the hi-limit is open, the green light on the GC-4A will be off. The light will come on within 5 seconds after a call for heat (24v to control) is initiated.

GC-4A CONTROL LIGHT IS OFF

1. Check that amber boiler switch light is ON. If switch light is OFF, check 110v power supply to boiler.
2. If switch light is ON, check that red boiler indicator light is ON. If red light is OFF, check thermostat, hi-limit and other operational controls.
3. If red light is ON, turn boiler power supply off. Remove six-pin connector from GC-4A. Turn power supply on. Check for 24v from connector pin #2 (brown wire) to a ground. If OK, reconnect it to GC-4A. If green GC-4A control light does not come on within 5 seconds, control is defective; replace it.

GC-4A CONTROL LIGHT IS ON

1. Observe light for 3-1/2 minutes (one attempt-for-ignition cycle).
2. If light remains ON but not blinking, turn power to boiler off. Remove one purple lead from combustion prove pressure switch PS1 and check contacts for continuity. If circuit is closed, replace the pressure switch. If circuit is open, GC-4A control is defective; replace it.
3. On AM-150, remove a lead from the blocked inlet pressure switch PS3 and check contacts for continuity. If circuit is open, replace the pressure switch. If circuit is closed, GC-4A control is defective; replace it.

GC-4A CONTROL LIGHT BLINKS (Red Boiler Indicator light ON)

1. Blinking light indicates control is operational; problem is elsewhere in boiler. However, gas valve circuit A and GC-4A ignitor should be checked. Turn boiler on/off switch off and on; this will reset GC-4A control and start an attempt-for-ignition cycle. From 25 to 40 seconds after resetting GC-4A, check that green boiler indicator light comes ON.
2. If green indicator light remains OFF, turn power to boiler off. Turn power to boiler back on. Place jumper across fan prove pressure switch PS2 terminals. After 25 to 40 seconds, check green indicator light comes ON. If green indicator light remains OFF, GC4A control is defective; replace it.
3. If green indicator light comes ON, check fan for proper operation and/or fan prove pressure switch PS2; replace as necessary. Also check ignition transformer as follows: Turn power to boiler off. Remove ignition lead from spud on the GC-4A control. Turn power to boiler on. After 25 seconds, when green indicator light comes ON, check for a spark with insulated screwdriver between control ignition spud and a ground. If spark is present, GC-4A is operating satisfactorily; refer to Troubleshooting Guide to correct problem. If there is no spark, check that white wire from quick connect fitting (adjacent to control ignition spud) to power supply neutral is securely fastened; if securely fastened and there is no spark, GC-4A control is defective; replace it.

APPENDIX A: GAS PIPE SIZING

Table A1 provides recommended gas header sizes for Pulse modular heating plants. For accurate size selection, be sure to use **total equivalent pipe length**; that is, the equivalent foot-length of all fittings, such as elbows, tees, and valves, used in the gas piping run. These can be determined from National Fuel Gas Code tables and must be added to the straight length of pipe as pipe sizing involves selecting the proper diameter. For the initial determination only, add 20% for the fittings to the straight length of piping to get a total equivalent length. However, once a diameter has been selected, the total equivalent length must be verified.

NO. OF MODULES			PIPE SIZE (IN.)
AM-100	AM-150	AM-300	
2	-	-	1"
3-4	2	-	1-1/4"
5-6	3-4	2	1-1/2"
7-9	5-6	3	2"
10-15	7-10	4-5	2-1/2"
16-24	11-16	6-8	3"
25-36	17-24	9-12	4"

TABLE A1: RECOMMENDED HEADER SIZES

GAS MAIN SIZING:

You need to know:

1. Total Btuh input of all modules in the heating plant.
2. Heating value of the natural gas in Btu per cubic foot, which can be obtained from the local gas utility.
3. Total equivalent length of the gas main.

Tables A2 and A3 are pipe sizing tables for natural gas and propane gas piping. They apply for sizing black iron pipe only and are based on total equivalent pipe length. Natural gas sizing table assumes a 1000 Btu/cu.ft. heating value for natural gas.

Gas Main (Natural Gas)

1. Determine the cubic feet of gas per hour for the total heating plant, using the following formula:

$$\frac{\text{Heating Plant Btuh Input}}{\text{NG Heating Value}} = \text{Cubic Feet Per Hour}$$

2. Determine total equivalent length of gas main.
3. In Table A2, find appropriate pipe length in upper portion of table under 'Length of Pipe, Feet' heading.

4. Move down the column; match the cubic feet per hour from Step 1. Higher capacity selection is acceptable.
5. Move across to the left-hand column 'Nominal Iron Pipe Size, Inches' and read required pipe size.
6. Once a diameter has been selected, verify the total equivalent length.

Gas Main (Propane)

1. Determine Btuh input for the total heating plant.
2. Determine total equivalent length of gas main.
3. In Table A3, find appropriate pipe length in upper portion of table under 'Length of Pipe, Feet' heading.
4. Move down the column; match the Btuh input from Step 1. Higher capacity selection is acceptable.
5. Move across to the left-hand column 'Nominal Iron Pipe Size, Inches' and read required pipe size.
6. Once a diameter has been selected, verify the total equivalent length.

Maximum Capacity of Pipe in Cubic Feet of Natural Gas per Hour for Gas Pressures of 0.5 Psig or Less and a Pressure Drop of 0.3 Inch Water Column
(Based on a 0.60 Specific Gravity Gas)

Nominal Iron Pipe Size, Inches	Internal Diameter, Inches	Length of Pipe, Feet													
		10	20	30	40	50	60	70	80	90	100	125	150	175	200
1/4"	.326	32	22	18	15	14	12	11	11	10	9	8	8	7	6
3/8"	.493	72	49	40	34	30	27	25	23	22	21	18	17	15	14
1/2"	.622	132	92	73	63	56	50	46	43	40	38	34	31	28	26
3/4"	.824	278	190	152	130	115	105	96	90	84	79	72	64	59	55
1"	1.049	520	350	285	245	215	195	180	170	160	150	130	120	110	100
1-1/4"	1.380	1,050	730	590	500	440	400	370	350	320	305	275	250	225	210
1-1/2"	1.610	1,600	1,100	890	760	670	600	560	530	490	460	410	380	350	320
2"	2.067	3,050	2,100	1,650	1,450	1,270	1,150	1,500	990	930	870	780	710	650	610
2-1/2"	2.469	4,800	3,300	2,700	2,300	2,000	1,850	1,700	1,600	1,500	1,400	1,250	1,130	1,050	980
3"	3.026	8,500	5,900	4,700	4,100	3,600	3,250	3,000	2,800	2,600	2,500	2,200	2,000	1,850	1,700
4"	4.026	17,500	12,000	9,700	8,300	7,400	6,800	6,200	5,800	5,400	5,100	4,500	4,100	3,800	3,500

TABLE A2

Maximum Capacity of Pipe in Thousands of Btu per Hour of Undiluted Liquefied Petroleum Gases (at 11 Inches Water Column Inlet Pressure)
(Based on a Pressure Drop of 0.5 Inch Water Column)

Nominal Iron Pipe Size, Inches	Length of Pipe, Feet											
	10	20	30	40	50	60	70	80	90	100	125	150
1/2"	275	189	152	129	114	103	96	89	83	78	69	63
3/4"	567	393	315	267	237	217	196	185	173	162	146	132
1"	1071	732	590	504	448	409	378	346	322	307	275	252
1-1/4"	2205	1496	1212	1039	937	834	771	724	677	630	567	511
1-1/2"	3307	2299	1858	1559	1417	1275	1180	1086	1023	967	866	787
2"	6221	4331	3465	2992	2646	2394	2205	2047	1921	1811	1606	1498

TABLE A3

APPENDIX B: CONTROL GUIDELINES

CONTROL SYSTEM METHODS

The objective of Pulse control systems is to relate fuel input to the actual heating load by automatic step-firing, which means that more or fewer heating modules are operated in response to automatic controls. Step-firing can be accomplished in many different ways to suit type and size of heating system. Hydrotherm has developed three basic levels of controls which meet most operating methods encountered.

Level I: Constant Water Temperature: Multiple aquastats set at increments of return temperature provide low cost step-firing control for small heating systems which operate with constant supply water temperature such as fan coil systems, etc. From a cold start, base modules fire and additional modules fire in accordance with settings of return water aquastats.

Level II: Outdoor Reset Supply Water Temperature (System J): Electronic, plug-in, modular control system designed to raise or lower the temperature of the supply water based on a proportional rise or drop in the temperature at the outside sensor by stage firing the modular boiler heating plant. This is an effective, low cost control system for small to medium heating plants (2-6 modules) where it is desired to modulate supply water temperature in relation to the outdoor temperature, such as in baseboard convector systems.

Level III: Outdoor Reset Supply Water Temperature
Especially designed for large modular Pulse heating plants, Hydrotherm Step Controllers provide stable, sequential firing of heating modules in up to 8 steps and are applicable for systems operating with constant or modulated supply temperatures.

CONTROL FUNCTIONS & DESCRIPTIONS

Combination Gas Valve: Factory-assembled with each module. Combines main shut-off cock, pressure regulator and a main magnetic gas valve, plus the added safe-

ty of a second in-line magnetic valve interlocked to assure absolute safe, reliable lighting. The 24-volt factory-mounted and wired transformer is required to operate the gas valve.

Immersion Aquastats: L4006A single and L4081A dual aquastats are used with modular Pulse heating plant Level I control system to open a control circuit in response to increasing water temperature. These may be used in multiples to provide step firing in response to either supply or return water temperature. In addition, a L4006A single aquastat is factory-assembled to each module as a hi-limit temperature safety control. **It is not meant for use as an operating control.** The factory mounted control includes an adjustable differential range of 5°F to 30°F. Supply water temperature is limited to 205°F by the factory-mounted component.

Manual Reset Hi-Limit: This is a safety control used in the modular Pulse heating plant control system to shut off all the boilers if the system temperature exceeds safe limits, usually 250°F. After cause for overheating has been remedied, the control must be reset manually by pushing the red button in the cover.

Outdoor Air Thermostat: This is a switching device used to turn on the system or system components at the desired outdoor temperature. The control has a 20-foot capillary tube, remote liquid filled bulb, and is supplied with a sunshield for mounting on a north wall where the sun's effects are minimized. The control box can be mounted anywhere within the length of the capillary tube. This outdoor thermostat is also used as a heat starter to automatically switch on system power to start the heating plant and system circulators. It is generally set at an outside temperature of 65°F.

System J: The basic control system consists of an "AR" reset module which accepts add-on "AA" winter/summer circulator starter, "Y" transformer mod-

ule, and “S” staging modules. Optional add-on modules include “D” temperature display module and “CLK” night set-back programmable clock. Five pin connectors between modules speed installation time and eliminate potential wiring errors. The modules can be mounted on any wall surface or an optional DIN rail.

Low Water Cut-Off: This is used to shut off the boilers in the event the water level should fall below a safe level. It is usually located in the supply header and may be obtained with an additional switch element to operate an alarm. Hydrotherm offers two types — electronic (RW700) or the float-type (#764).

Diverting Valves: Diverting valve with end switch, such as a 24 volt V8044E, is commonly used for combination space/volume water heating application where a single AM-100 or AM-150 module is being diverted. Larger valves are required with AM-300 and where multiple boilers are diverted. These valves function to divert flow of boiler water from space heating to storage tank water heating coil or external heat exchanger.

Electronic Outdoor Reset Step Control: Solid state Model S electronic outdoor reset step control has been

designed specifically to reset system supply temperature in relation to outdoor temperature for large heating plants by step-firing the required number of modules for desired system supply temperature. Model S control consists of all solid state components as follows:

1. Outdoor temperature and heat starter sensor mounted, preferably, on the north side of the building.
2. Supply water temperature sensor mounted in Multi-Pulse supply piping (5 ft. downstream of all modules).
3. Control box for mounting in the boiler room including microprocessor, L.E.D. indicating lights, and supply and air temperature digital read out.

The center of the control box is a microprocessor which monitors the resistance of the outdoor and supply water temperature sensors. Changes in temperature, at either of the sensing elements, causes the controller to increase or decrease the number of boilers firing to maintain the required supply water temperature. The controller will handle up to eight heating steps and also includes power off alarm relay and outdoor actuated system heat starter. Optional equipment includes night set-back controller & boiler service on-time/cycle counter.

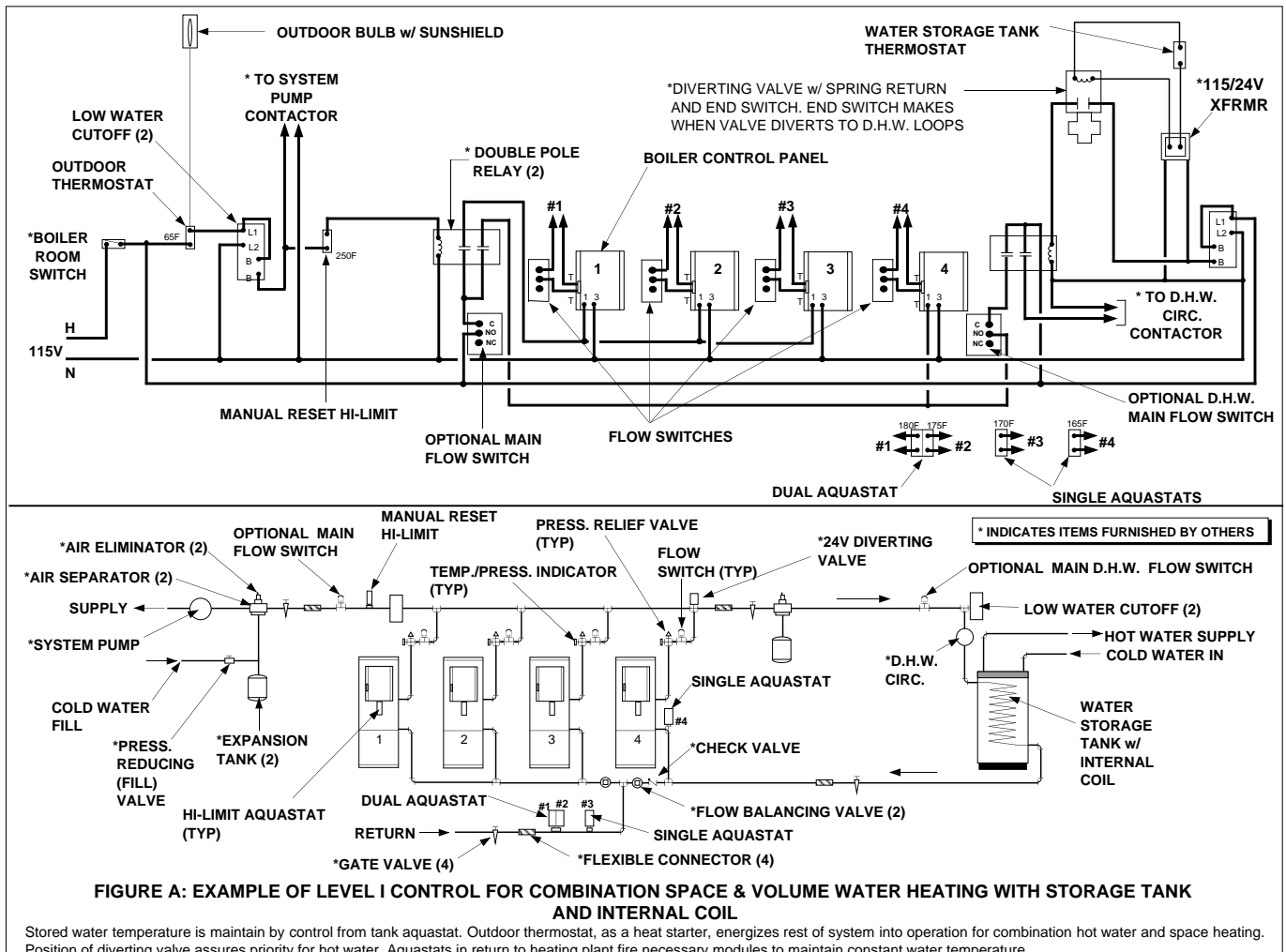

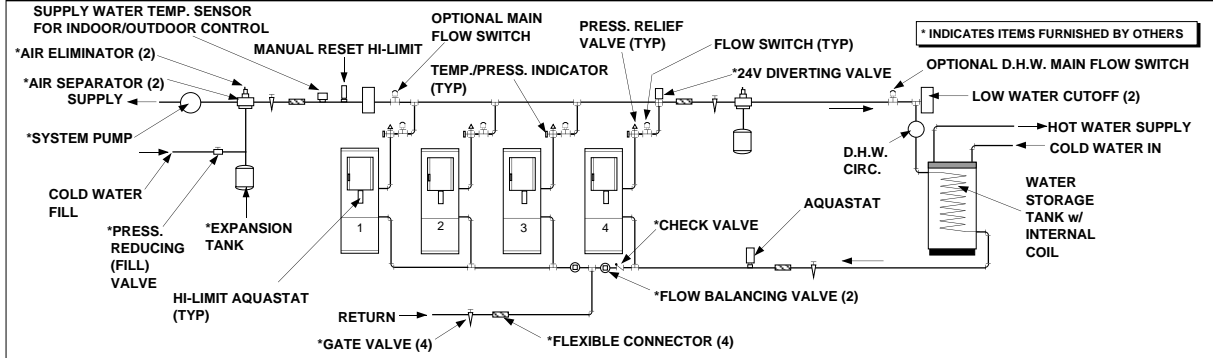
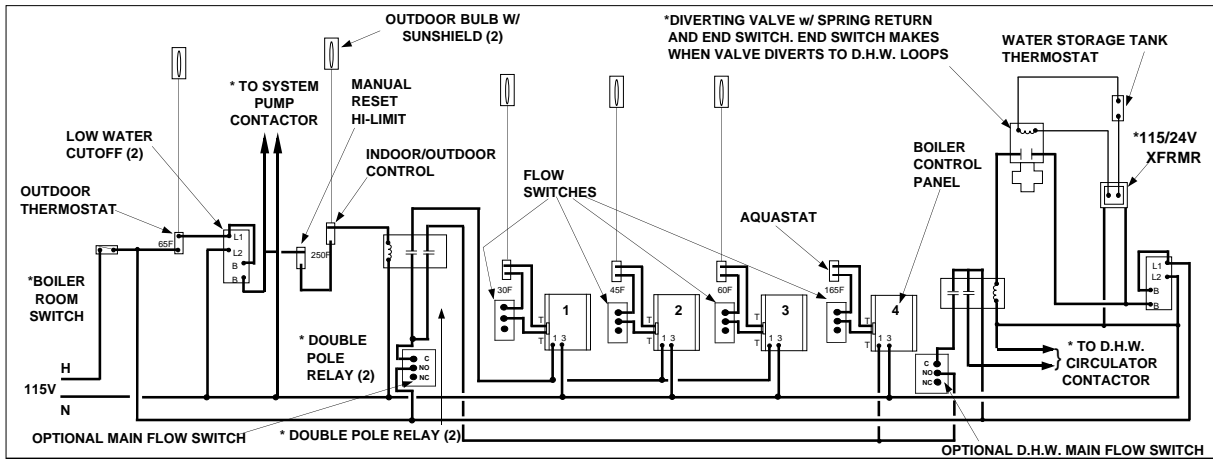

FIGURE B: EXAMPLE OF LEVEL II CONTROL FOR COMBINATION SPACE & VOLUME WATER HEATING WITH STORAGE TANK AND INTERNAL COIL

For space heating, outdoor thermostat, as a heat starter, energizes system into operation. Indoor/outdoor control resets boiler supply water temperature in relation with outdoor temperature. Supplemental outdoor thermostats increase number of modules that are fired by indoor-outdoor control in accordance with outdoor temp. For water heating, tank aquastat energizes diverting valve, fires #4 module and start DHW circulator until tank aquastat is satisfied, at which time diverting valve is de-energized for flow of water through #4 module to space heating system.

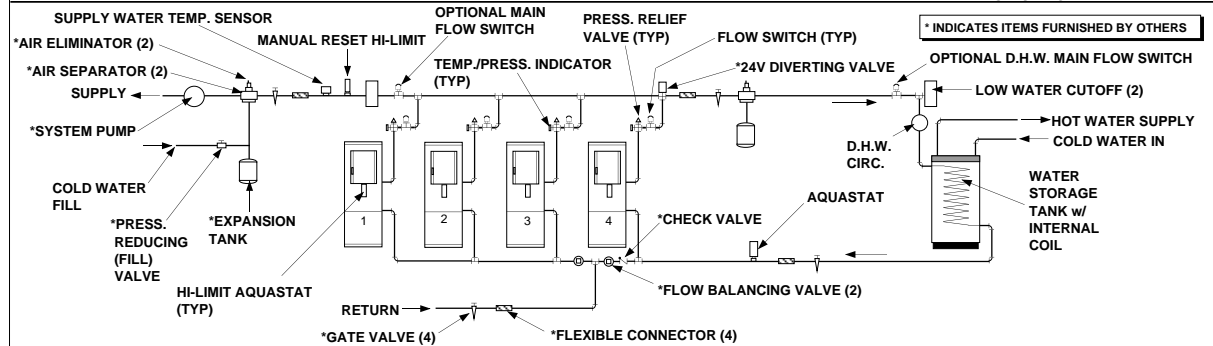
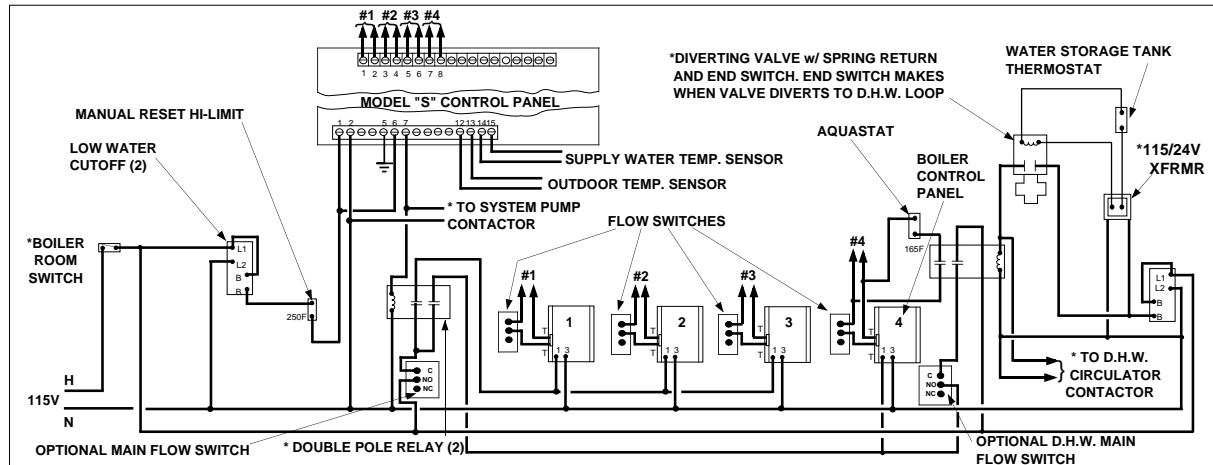
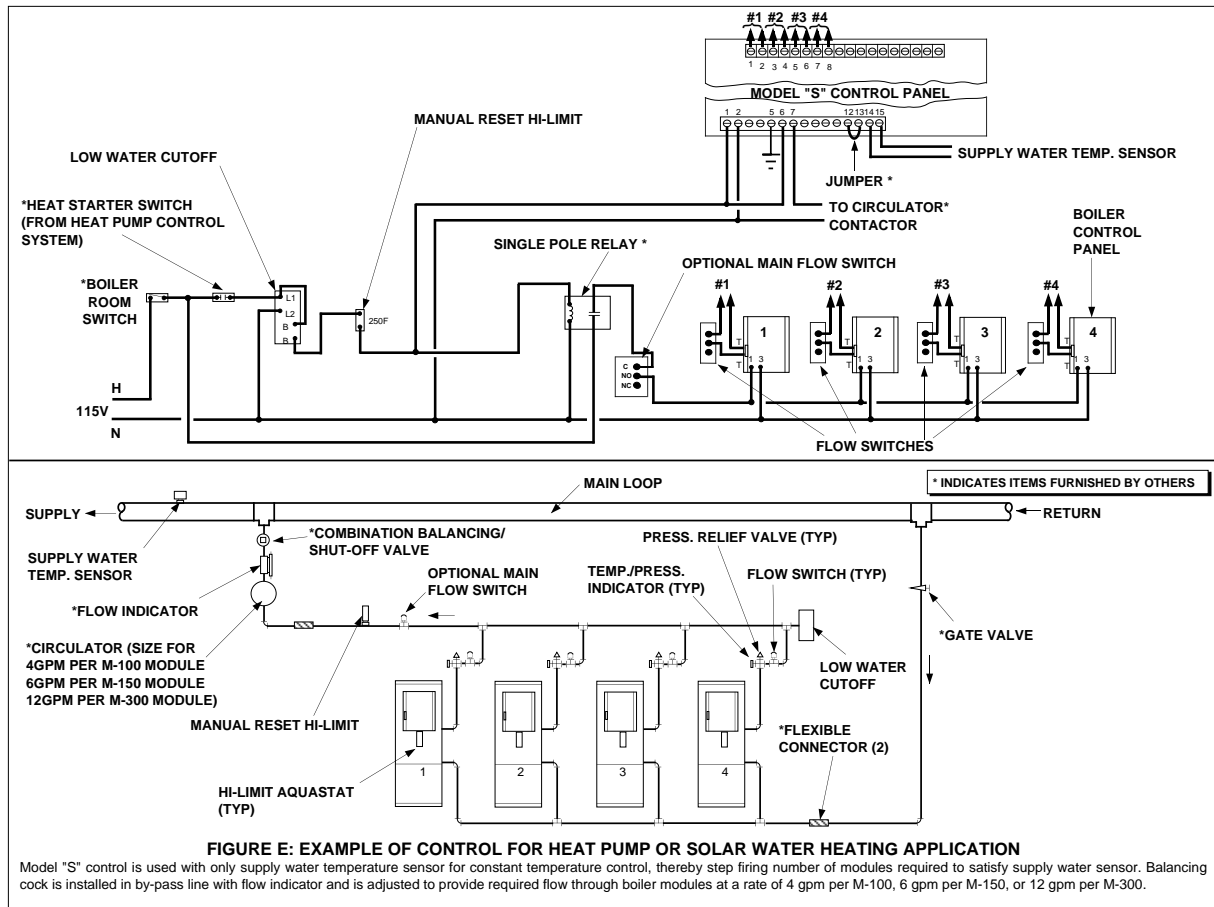
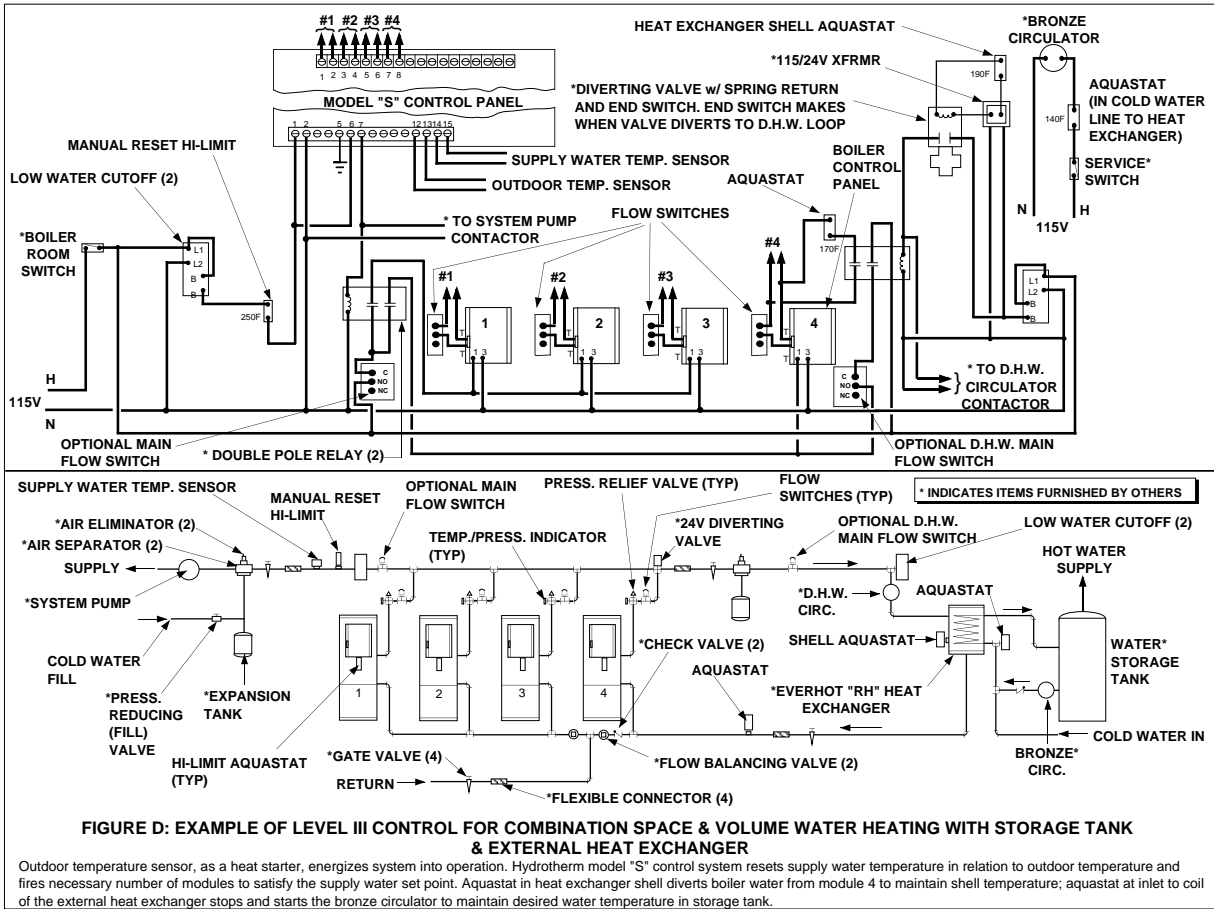

FIGURE C: EXAMPLE OF LEVEL III CONTROL FOR COMBINATION SPACE & VOLUME WATER HEATING WITH STORAGE TANK AND INTERNAL COIL

Outdoor temperature sensor, as a heat starter, energizes system into operation. Hydrotherm model "S" control system resets supply water temperature in relation to outdoor temperature and fires necessary number of modules to satisfy supply water temperature. For domestic hot water, tank aquastat energizes diverting valve, fires #4 module and starts DHW circulator until tank aquastat is satisfied, at which time diverting valve is de-energized for flow of water through #4 module to space heating system.



AM SERIES PULSE BOILER RESIDENTIAL INSTALLATIONS

PART II – RESIDENTIAL INSTALLATION TABLE OF CONTENTS

SECTION 1: INTRODUCTION	34	SECTION 5: CONDENSATE LINE	43
SECTION 2: LOCATING/SETTING BOILER	35	SECTION 6: GAS PIPING	
SECTION 3: WATER PIPING		Select Gas Pipe Size	44
Planning Ahead	35	Connecting Gas Piping	45
Piping Tree Components	35	Testing Gas Piping	45
Install Water Piping	36	SECTION 7: WIRING	46
Install Hydronic Components	36	SECTION 8: START-UP & OPERATION	
Hydrotesting The System	37	Sequence Of Operation	52
SECTION 4: VENTING		Purging & Start-Up	53
Planning Ahead	38	Lighting Instructions	54
Dormant Chimney Installation	40	Operation Adjustments	55
Through-The-Roof Installation	41	Maintenance	56
Through-The-Wall Installation	42	SECTION 9: TROUBLESHOOTING	57

The following terms are used throughout this manual to bring attention to the presence of potential hazards or to important information concerning the product:

DANGER: Indicates an imminently hazardous situation which, if not avoided, will result in death, serious injury or substantial property damage.

WARNING: Indicates a potentially hazardous situation which, if not avoided, could result in death, serious injury or substantial property damage.

CAUTION: Indicates a potentially hazardous situation which, if not avoided, may result in minor injury or property damage.

NOTE: Used to notify of special instructions on installation, operation or maintenance which are important to equipment but not related to personal injury hazards.

SECTION 1: INTRODUCTION

BOILER DESIGN: The Pulse is an advanced technology, high efficiency, automatic, gas fired, direct vent water boiler which utilizes the pulse combustion principle. As such, it requires no burners, no pilot flame, no flue and no chimney. For combustion, the boiler uses 100% outside air, supplied through Schedule 40 Poly Vinyl Chloride (PVC) pipe. Products of combustion are vented to the outdoors through Schedule 40 Chlorinated Poly Vinyl Chloride (CPVC) pipe. Pipe can be routed either through a dormant chimney, a roof or an outside wall.

Gas and water connections are similar to conventional systems; however, **DO NOT ATTEMPT TO START BOILER, EVEN MOMENTARILY, BEFORE FILLING AND PURGING BOILER AND SYSTEM AS A DRY-FIRE CONDITION WILL RESULT IN BOILER DAMAGE WHICH IS NOT COVERED BY WARRANTY.**

The Pulse boiler is covered by the following U.S. Patents: 3,267,985; 4,241,720 and 4,241,723.

CODE COMPLIANCE: Installations must conform to requirements of authority having jurisdiction or, in absence of such requirements, to National Fuel Gas Code ANSI Z223.1-latest edition. Where required by authority having jurisdiction, installation must also conform to the Standard for Controls & Safety Devices for Automatically Fired Boilers, ANSI/ASME - CSD-1.

All electrical wiring must be in accordance with requirements of authority having jurisdiction or, in absence of such requirements, with National Electric Code NFPA -

70-latest edition and any additional state or local code requirements. If an external source is utilized, installed boiler, must be electrically grounded in accordance with the requirements of authority having jurisdiction or, in absence of such requirements, with National Electric Code ANSI/NFPA-70-latest edition. UL listed power limited circuit cable is almost universally approved for safety controls on heating equipment, either internally or externally, without protection of conduits or raceway.

For Canada, the installation must be in accordance with Standards CAN/CGA B149.1 or .2 Installation Codes for Gas Burning Appliances and Equipment and with Standard C.S.A. C22.1 Canadian Electrical Code, Part 1 and Part 2, and/or local codes.

WARNING: Installers must follow local regulations with respect to the installation of CO detectors and follow the manufacturer's stated maintenance schedule for this boiler!

ATTENTION: Observer les règlements régional à l'égard des détecteurs de monoxyde de carbone et observer entretien de manufacturier pour cette chaudière!

BOILER SHIPMENT: Each boiler is shipped in a single carton and weighs 265 lbs (AM-100) or 436 lbs. (AM-150). A supply water piping tree assembly is packed with each boiler.

BOILER MODEL	DIMENSIONS (INCHES)												
	A	B	C	D	E	F	G	H	J	K	L	M	N
AM-100	40"	14"	5-5/8"	35-1/2"	10-3/8"	43-1/2"	1"	1-1/2"	23-1/2"	1-1/2"	16"	50"	25-3/4"
AM-150	47-1/4"	17"	4"	42-11/16"	14-1/8"	51-3/4"	1-1/4"	2"	27"	1-5/8"	23-3/4"	58"	30-3/4"

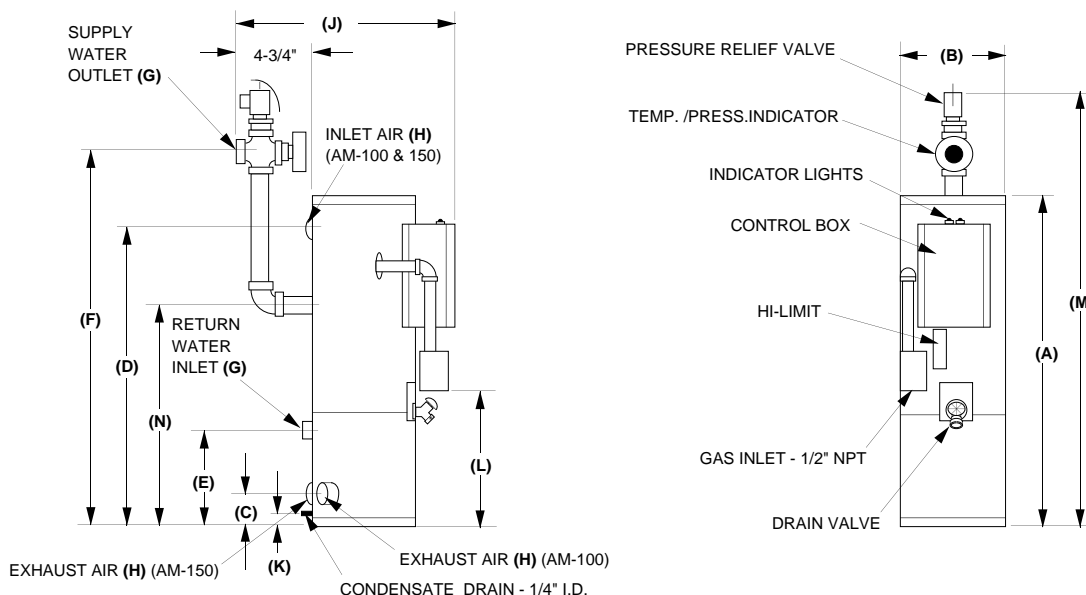

MODELS AM-100 & AM-150 DIMENSIONS

SECTION 2: LOCATING & SETTING BOILER

Boiler may be installed in heated basement, utility room, garage or closet. For basements, avoid placing boiler under any sleeping areas. For closets, check for insulation between the layers of sheetrock or consider lining closet with acoustical tile to deaden sound.

WARNING: Never install boiler on carpeting.

Observe the minimum clearances to combustibles as shown in Figure 2.1. Local requirements may specify greater clearances and must be adhered to. Units are approved for installation on combustible flooring.

DO NOT install this boiler in a location that would subject any of the gas ignition components to direct contact with water or excessive moisture during operation or servicing.

Air intake and exhaust pipe sizes, piping runs between boiler and outdoors, and vent terminations must be in accordance with the venting requirements detailed in Part II, Section 4 in this manual.

Never install boilers or vent piping in an unconditioned area where condensate will be subject to freezing temperatures.

BOILER MODEL	Minimum Clearances To Combustibles (In.)			
	TOP	FRONT	SIDES	REAR
AM-100	24"	6"	0"	0"
AM-150	24"	6"	0"	0"

FIGURE 2.1

Solid pedestal, to support boiler weight, will be required if an in-the-floor drain is not available to collect condensate. The pedestal must be of sufficient height to permit gravity draining of condensate.

Resilient pad under the boiler is recommended when installed in or above a living space to reduce vibrations being transmitted into floor or living space.

Because of its weight and the importance of protecting internal components, always use a good hand truck to move the boiler.

CAUTION: Avoid excessive bouncing when moving boiler down a stairwell.

SECTION 3: INSTALLING WATER PIPING

PLANNING AHEAD

WATER TREATMENT: Recommended in areas where water quality is a problem; must be used in hard water areas and on very large volume heating systems. Local water treatment company should be consulted to determine requirements for your system and locality.

NOTE: Boilers not for use in systems where water is replenished. Minerals in water can build up on heat transfer surfaces and cause overheating and subsequent failure of the heat exchanger.

FREEZE PROTECTION: Where it's necessary, anti-freeze can be used but must be compatible with hydronic systems. System must be designed to accommodate necessary changes in heat transfer, pump head, flow rate, and expansion. Consult The Hydronics Institute Technical Topics Number 2A publication.

NOTE: Never use an RV-type antifreeze protection solution nor an automotive-type antifreeze as damage to boilers and other system components may result.

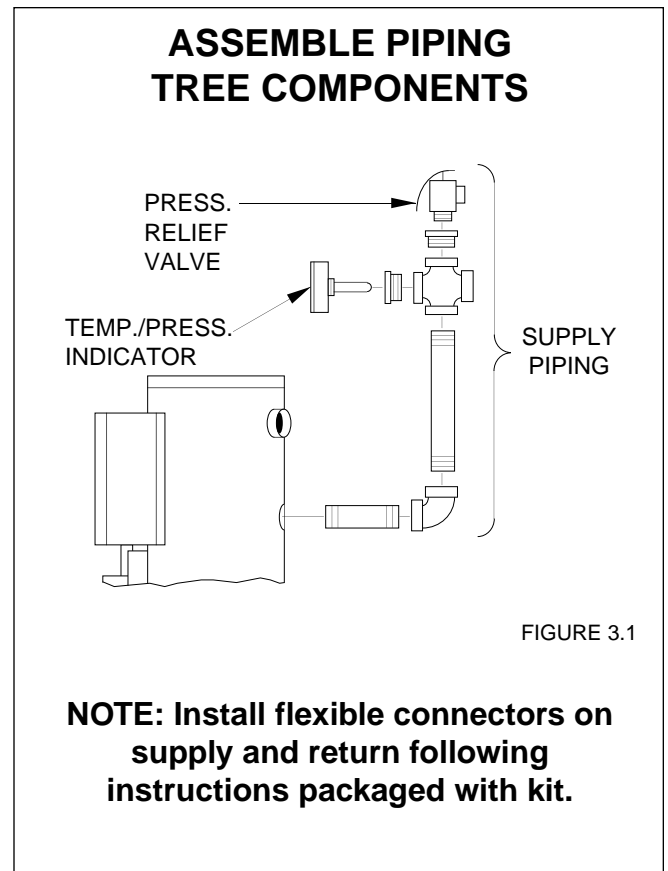

FIGURE 3.1

NOTE: Install flexible connectors on supply and return following instructions packaged with kit.

INSTALL WATER PIPING

Select pipe size based on the required minimum flow rates, as provided in Figure 3.2. We recommend using flow rates based on 20° F temperature rise. Unlike conventional boilers, the Pulse must not be allowed to fire unless minimum water flow rates are provided to boiler, as irreparable boiler damage may result.

NOTE: On zoned systems, make sure zone with highest flow restriction, typically the longest zone, will allow proper minimum flow rate.

All external piping must be supported by hangers, not by boiler or accessories.

When connecting pipe ends within the optional flexible connector, do not let them touch each other, see Figure 3.3.

Note: Hydrotherm recommends the use of the optional flexible connector (vibration isolating kit) part #BM7252AM100 and BM7253AM150.

Boiler Model	Fuel	Input (Mbh)	Heat Cap. (Mbh)	Water Flow - (Gpm)	
				System Design ΔT (°F)	
				20	40
AM-100	NG	100	88.0	8.8	4.4
	LP	90	80.0	8.0	4.0
AM-150	NG	150	132.0	13.2	6.6
	LP	135	122.0	12.2	6.1

FIGURE 3.2

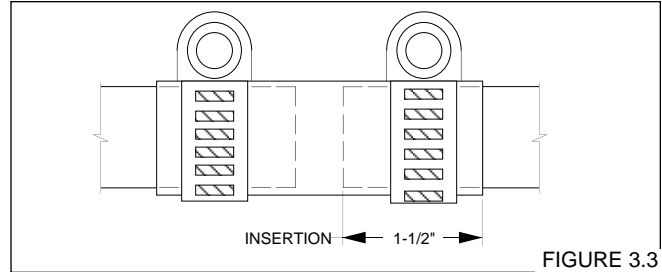

FIGURE 3.3

INSTALL HYDRONIC COMPONENTS

Figures 3.5 and 3.6 show typical locations of hydronic components required for Pulse boilers. In all cases, installation should be in accordance with component manufacturer's recommendations. Literature, if applicable, is packaged with each component. In addition, the following guidelines should be used:

PRESSURE RELIEF VALVE: Should have been installed with supply water piping tree with spindle in vertical position, valve discharge in horizontal. Install field-supplied relief valve discharge piping, which must be same size or larger than valve outlet & terminate 6" above floor.

WARNING: No valve of any type may be installed between the boilers and the relief valve or an explosion from over-pressurization may occur!

CAUTION: Piping must be installed from the relief valve discharge so there will be no danger of scalding personnel.

TEMPERATURE/PRESSURE INDICATOR: Should have been installed with supply water piping tree.

AIR SEPARATOR: Locate in the supply line between boiler and system pump where it will protect boiler under all operating conditions. Follow manufacturer's installation instructions.

AIR ELIMINATOR: Install on air separator where it will protect boiler under all operating conditions. Follow manufacturer's installation instructions.

EXPANSION TANK: Locate on suction side of pump where it will protect boiler under all operating conditions.

Follow manufacturer's instructions.

PRESSURE REDUCING (FILL) VALVE: Follow manufacturer's installation instructions.

LOW WATER CUTOFF: (Electronic type or float type) Locate in supply line. Follow manufacturer's installation instructions. If boiler is to be installed above level of radiation, a low water cut-off must be installed to protect boiler from dry fire.

CAUTION: To prevent accidental dry fire, do not install isolation valves between low water cutoff and the boiler.

CAUTION: Do not install any low water cut-off in a location where water will not freely drain away from the float or probe, such as in a pipe tree or loop, should a low water condition develop in the boiler.

For electronic probes, a vertical installation where all water can freely drain away from probe is preferred over horizontal. Do not install in small diameter pipe nipples or bushings, as insufficient clearance to probe may result in corrosion and/or erroneous readings.

SYSTEM PUMP: Must be selected for system design flow rate and anticipated head loss through the piping system. Locate in supply piping, downstream of boiler. Follow manufacturer's installation instructions.

FLOW SWITCH: Flow switches are required to prevent heat exchanger damage due to leaks or insufficient water flow. Follow the manufacturer's installation instructions. Install in horizontal position.

INSTALL HYDRONIC COMPONENTS (continued)

NOTE: Boiler must not be used without forced system circulation, as overheating or failure of heat exchanger may result.

OTHER COMPONENTS: Install all other waterside components such as manual purging valves, flow switches, and shut-off valves in all loops and zones. Follow manu-

HYDROTESTING THE SYSTEM

1. Check that the flow direction arrows on all hydronic components, circulators, zone valves, check valves, pressure reducing valve, manual purging valves, air separators, etc., are facing in the proper direction.

2. Fill entire system with water and pressurize. Inspect all fittings & components for visible signs of leakage. If no pressure drop is detected for a two-hour period under pressure, system may be considered water tight.

TYPICAL PIPING FOR HEATING & COOLING SYSTEMS

If a hot water boiler is installed in connection with a water chiller, the chilled water must be piped in parallel with the boiler, using appropriate valves to prevent the chilled medium from entering the boiler, see Figure 3.4. When boilers are connected to heating coils located in air handling units where they may be exposed to refrigerated air circulation, such boiler piping system shall be equipped with flow-control valves or other automatic means to prevent gravity circulation of the boiler water during the cooling cycle.

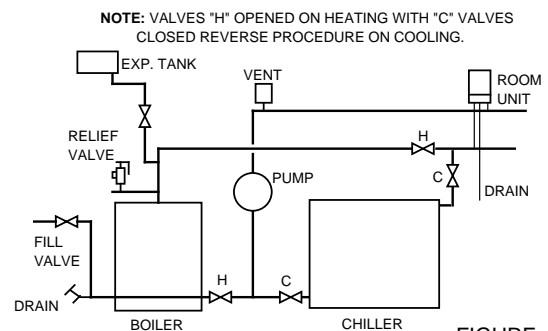

TYPICAL PIPING FOR RESIDENTIAL SPACE HEATING SYSTEM

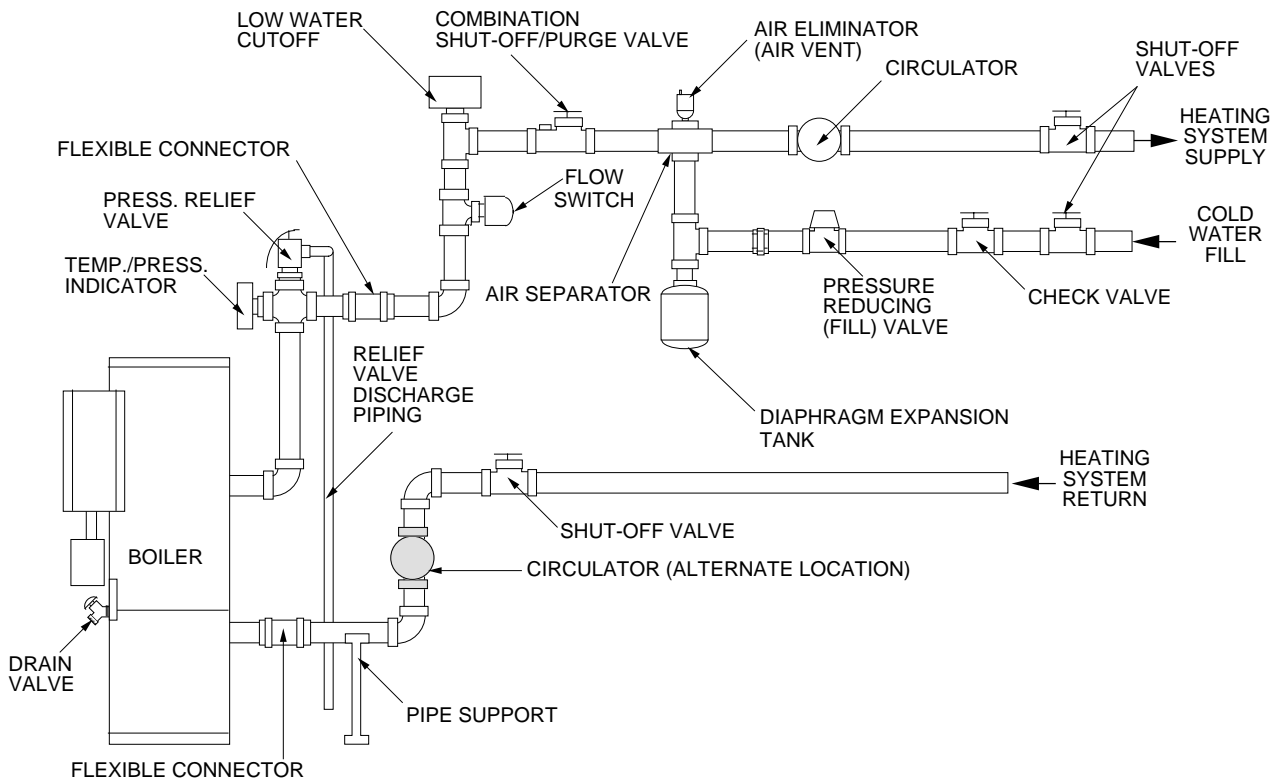

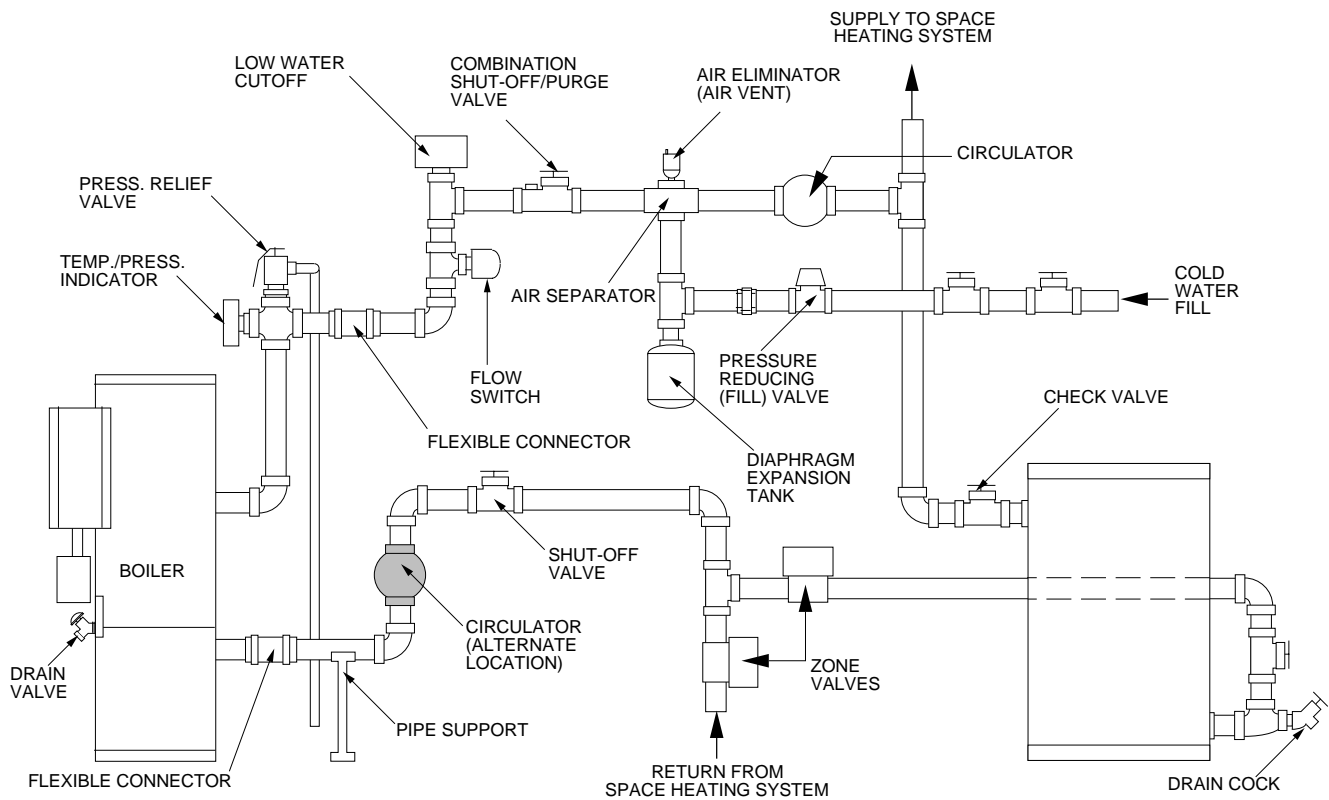

FIGURE 3.6

SECTION 4: VENTING THE BOILER

PLANNING AHEAD

WARNING: This boiler must be vented in accordance with Part 7, Venting of Equipment, of the latest edition of the National Fuel Gas code, ANSI Z223.1 and all applicable local building codes. In Canada, follow CAN/CGA B149.1 or .2 Installation Codes. Improper venting of this appliance can result in excessive levels of carbon monoxide which can result in severe personal injury or death!

VENT PIPING REQUIREMENTS

1. Boiler is equipped with air intake and exhaust connections located at the rear of the boiler. Air intake is at top; exhaust is at bottom. Both connections are female plastic fittings designed to accept 1-1/2" pipe for AM-100 or 2" pipe for AM-150.

2. Air intake piping **MUST BE** Schedule 40 Poly Vinyl Chloride (PVC) pipe. Exhaust piping **MUST BE** Schedule 40 Chlorinated Poly Vinyl Chloride (CPVC) pipe. Both must be vented separately, through a roof, wall or dormant chimney. Piping between boiler and outdoors must be within following permissible lengths, see Figure 4.1:

Model AM-100: Maximum of 25 running feet of 1-1/2" pipe with 6 elbows; or maximum of 40 running feet of 2" pipe with 6 elbows; or maximum of 100 running feet of 3"

pipe with 6 elbows. Minimum of 6 feet with 2 elbows. For natural and propane gas usage.

Model AM-150: Maximum of 40 Nat/25 LP running feet of 2" pipe with 6 elbows; or maximum of 100 running feet where first 40 feet is 2" pipe with 5 elbows maximum followed by 60 feet of 3" pipe with 4 elbows maximum. To avoid a condensate trap, transition from 2" to 3" pipe must be made in a vertical run. Minimum of 6 feet with 2 elbows. For natural or propane gas usage.

NOTE: Do not use pipe having different diameters except where noted for the AM-150 and on the air intake termination on LP AM-100s using 3" pipe.

3. Both air intake and exhaust piping must be routed as directly as possible and must not be manifolded. All piping runs must be sloped toward the boiler with a pitch of at least 1/4" or more per foot.

CAUTION: Failure to pitch piping runs properly can result in a condensate trap which can restrict venting and result in an inoperative boiler.

4. There must be no low spots in either piping run. A high spot is acceptable in either piping run, provided the

PLANNING AHEAD (continued)

VENT PIPING AND MUFFLERS							VENT TERMINATION				
							THROUGH THE WALL			DORMANT CHIMNEY & THRU ROOF (4)	
Boiler Model	Type of Vent	Pipe size (1)	Trans. at Boiler (2)	Max. Running Feet of Pipe (3)	Max. No. of Elbows (3)	Muffler Size	Air Intake Pipe (2)	Vent Terminal Plate		12" Exhaust Extension	Air Intake 180° Ell (2)
								Size	Coupling		
AM-100	Exhaust	1 1/2"	---	25	6	1-1/2" x 41"	---	1-1/2"	---	1-1/2"	---
	Air Intake	1 1/2"	---	25	6	1-1/2" x 22"	3 x 36	3"	3" x 1-1/2"	---	1-1/2"
AM-100	Exhaust	2"	2" x 1-1/2"	40	6	2" x 41"	---	3"	---	2"	---
	Air Intake	2"	2" x 1-1/2"	40	6	2" x 24"	3 x 36	3"	3" x 2"	---	2"
AM-100	Exhaust	3"	3" x 1-1/2"	100	6	3" x 41"	---	3"	---	3"	---
	Air Intake	3"	3" x 1-1/2"	100	6	3" x 41"	3 x 36	3"	---(5)	---	3"(5)
AM-150	Exhaust	2"	---	40	6	2" x 41"	---	3"	---	2"	---
	Air Intake	2"	---	40	6	2" x 22-1/2"	3 x 36	3"	3" x 2"	---	2"
AM-150	Exhaust	2" + 3"	---	40(2") + 60(3")	5(2") + 4(3")	2" x 41"	---	3"	---	3"	---
	Air Intake	2" + 3"	---	40(2") + 60(3")	5(2") + 4(3")	2" x 22-1/2"	---	3"	---	---	3"

(1) Mixing of pipe sizes during run is not allowed, except for AM-150 as shown. (2) Field-supplied materials. (3) Minimum of 6 running feet with 2 elbows. (4) For dormant chimney and through-the-roof installations, exhaust pipe termination must be 12" longer than the air supply termination. (5) For Propane Only - Use 3" x 1½" reducer coupling on intake termination.

FIGURE 4.1

pitch from the high spot is maintained back to the boiler and to the outside point of air intake or exhaust.

5. Avoid rigid connections between piping and structural members of building. Piping must be supported with vibration isolating hangers to prevent transmission of vibrations into structure. To avoid possible sagging on horizontal runs that can result in condensate traps, maximum spacing between the piping supports must not exceed 7-feet for air intake and 5-feet for exhaust. For long horizontal runs, continuous support, closer spacing of supports or increased pitch of piping runs should be used to avoid condensate traps.

6. At horizontal to vertical piping transitions, sufficient support must be provided to prevent sagging at end of horizontal runs and support weight of vertical riser.

7. Avoid routing vent piping internally through walls, ceilings, in close proximity to any exposed ductwork, or under any sleeping areas.

8. Always allow sufficient access to the vent piping for annual inspection.

9. Carefully prepare and cement all pipe and elbows together including boiler connections. Use proper solvent cementing techniques. Remove all burrs and shavings from the ends of cut pipe prior to cementing.

NOTE: Improperly cleaned/de-burred joints may

result in pipe shavings/burrs being carried back to boiler by condensate; this will result in clogged condensate drain fittings.

VENT TERMINATION REQUIREMENTS

1. In U.S., vent terminations must meet the following requirements: Minimum clearance of 4-ft horizontally from nearby electric meters, gas meters, regulators and relief equipment; minimum of 12" from any opening through which flue gases could enter the building; minimum of 3-ft above a forced air inlet located within 10-ft; minimum of 12" above grade and normal snow line to bottom of terminal or minimum of 7-ft above grade if venting adjacent to public walkway.

2. In Canada, vent termination must meet the following requirements: Minimum of 6-ft from a combustion air inlet of another appliance; minimum of 3-ft from any other building opening or any gas service regulator; not directly above a gas utility meter or service regulator; minimum of 12" above grade and normal snow line to bottom of terminal or minimum of 7-ft above grade if venting adjacent to public walkway.

3. When selecting a vent terminal location, consideration must be given for the sound and vapor which will be present at the termination point. Due to the condensing vapor, avoid terminating where slightly acidic moisture and/or frost can damage building materials. Be advised that some discoloration of the outside wall can occur, due to the condensing vapor.

PLANNING AHEAD (continued)

4. Avoid vent terminal locations near sources of contaminated air such as building exhaust vents, equipment vents, air conditioning and refrigeration equipment. Avoid locating boiler exhaust terminations near building ventilation air intakes.

5. To prevent slippery conditions, or where the presence of condensate from exhaust outlet will be objectionable, avoid venting over any sidewalk, driveway or mechanical equipment.

6. To maintain outdoor sound at a minimum and assure a free open area where exhaust gases can be properly

dispersed, avoid venting into narrow alleyways or alcoves, at neighboring windows, in any window well or near bedroom windows. In other venting situations, where outdoor sound may be objectionable, mufflers must be installed to reduce sound.

7. For through-the-wall or through-the-roof installations air intake and exhaust terminations must be separated from 18" minimum to 8-ft maximum ON THE SAME WALL OR ROOF.

DORMANT CHIMNEY INSTALLATION

1. When running piping up through an existing chimney, be sure chimney and flue are dormant; that is, not connected to a fireplace, water heater or any other heating appliance. In Canada, the exhaust vent shall not be run through interior part of an open chimney unless the exhaust vent is insulated.

2. Air intake pipe termination must be as shown in Figure 4.2, with a 180° ell installed on air intake pipe.

3. Exhaust pipe termination must be 12" longer than air intake pipe to prevent exhaust recirculation.

For 3" piping on Propane AM-100, cement a reducer coupling and short tubing transition to the inlet termination only, see Figure 4.2.

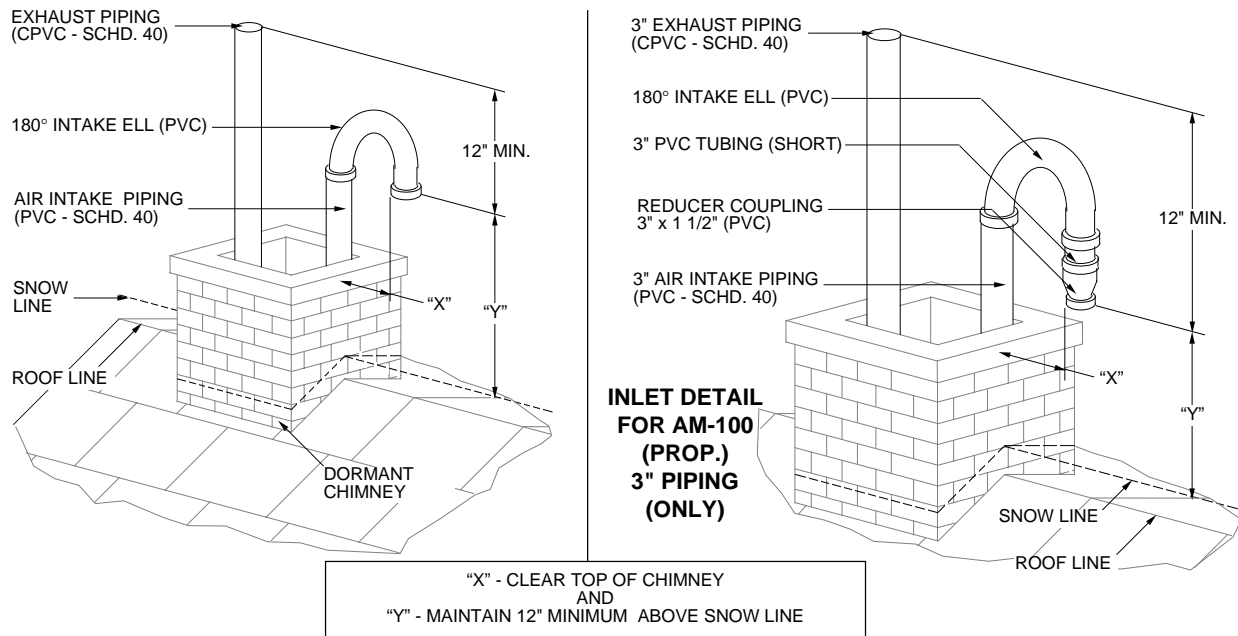

FIGURE 4.2

THROUGH-THE-ROOF INSTALLATIONS

Each air intake pipe termination must have a 180° ell installed. Each exhaust pipe termination must be at least 12" longer than the air intake, see Figure 4.3.

For 3" piping on Propane AM-100, cement a reducer coupling and short tubing transition to the inlet termination only. Refer to detail in Figure 4.4 and additional clearance information figures.

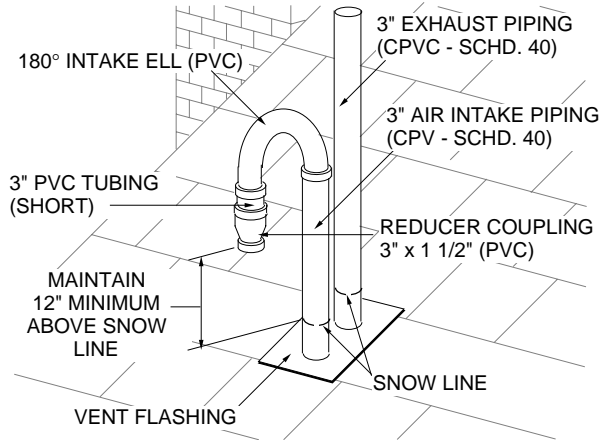

FIGURE 4.4

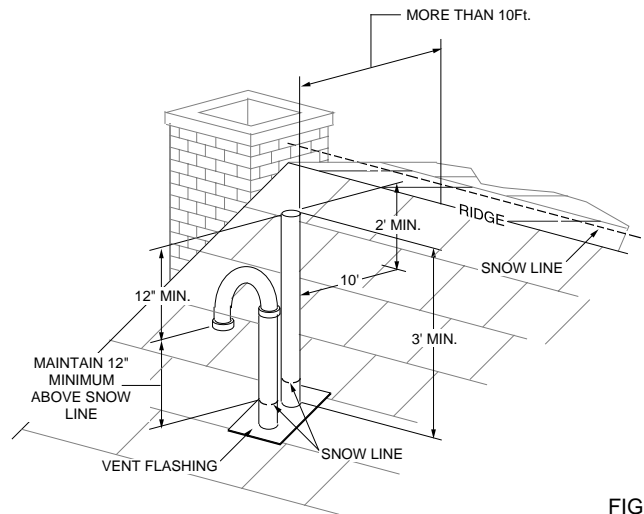
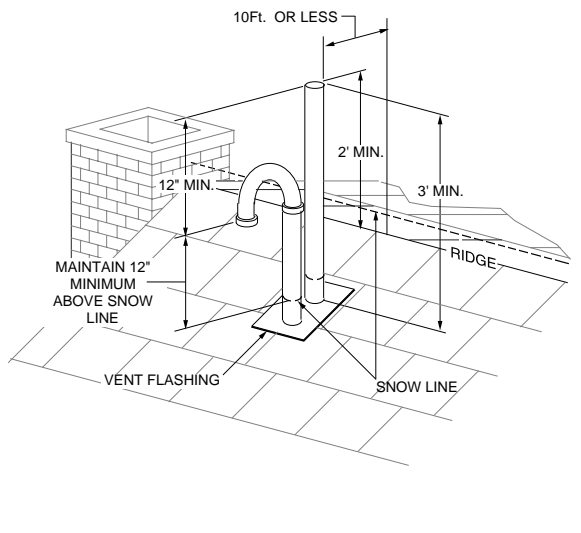

FIGURE 4.3

THROUGH-THE-WALL INSTALLATIONS

Air intake/exhaust terminations must be separated 18" minimum to 8-ft. maximum ON THE SAME WALL. Exhaust outlet must be installed ABOVE the air intake to prevent exhaust recirculation. If mufflers are required, follow installation instructions packaged with muffler sets. Protect all terminations from vermin, etc.

with terminal plates, see Figures 4.5 & 4.6.

For 3" piping on Propane AM-100 cement a reducer coupling and short tubing transition to the inlet termination only as shown in Figure 4.5A.

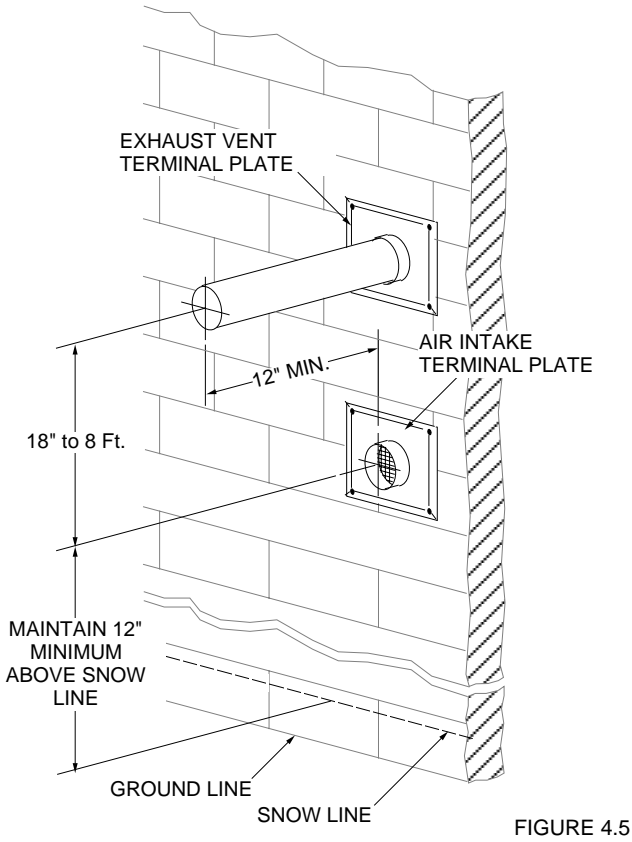
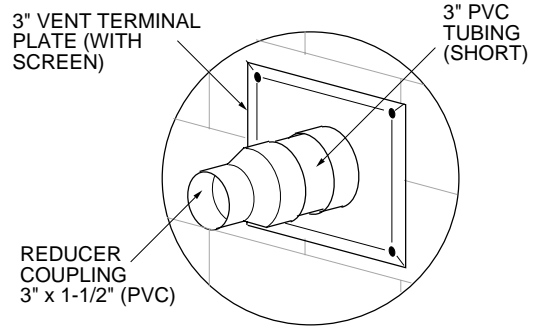
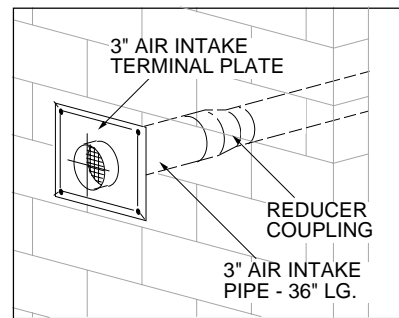

FIGURE 4.5



AIR INTAKE PIPING TERMINATION DETAIL
AM-100 (PROPANE) 3" PIPING (ONLY)

FIGURE 4.5A



AIR INTAKE PIPING
FOR INSTALLATIONS USING
2" AND UNDER PIPE ONLY

FIGURE 4.6

CONCENTRIC VENT TERMINAL (OPTIONAL)

For through-the-wall venting on **residential applications only**, a concentric vent terminal is recommended, see Figure 4.7. Follow installation instructions packaged with Concentric Vent Terminal Kit.

However, where a concentric vent terminal will not fit, use separate air intake and exhaust vent terminals as shown in Figures 4.5 & 4.6.

NOTE: Concentric vent terminals are for residential installations only and may be used for through-the-wall venting only. They cannot be used for dormant chimney or through-the-roof venting.

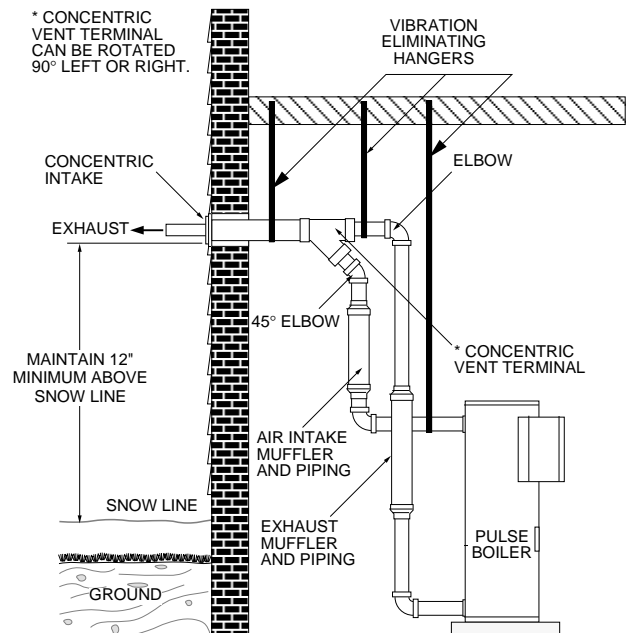

FIGURE 4.7

MUFFLER SET INSTALLATION

Exhaust and air intake mufflers may be installed with air flow in either direction. They take the place of an equivalent pipe length. Mufflers **MUST BE** installed as close to the boiler as possible and as close to vertical as possible (see Figure 4.8). Mufflers **MUST NEVER BE INSTALLED HORIZONTALLY**. If necessary, mufflers can be mounted on a 45-degree angle (see Figure 4.9).

NOTE: If the muffler is to be installed at an angle, make sure the 1/4" drain hole on the inside of the coupling is at the bottom of the pipe for downward draining.

Mufflers with 1-1/2" end couplings (BM-6021/6022) must be used with 1-1/2" pipe only. Mufflers with 2" end couplings (BM-6030/6031) must be used with 2" pipe only. Mufflers with 3" end couplings (BM-6082/6083) must be used with 3" pipe only. **DO NOT** alter or reduce the inlet or outlet connections on muffler.

Using a file or emery cloth, remove any burrs from the cuts you made in the vent piping. First, try the muffler for proper fit. Then, using a moderate amount of the appropriate cement, install the muffler in place. Since the muffler weighs more than an equivalent section of pipe, it must be supported (see Figures 4.8 and 4.9). Use either a vibration isolating floor stand or, if more convenient, a vibration isolating floor hanger nailed to a joist. In both cases, the support must be close to the muffler.

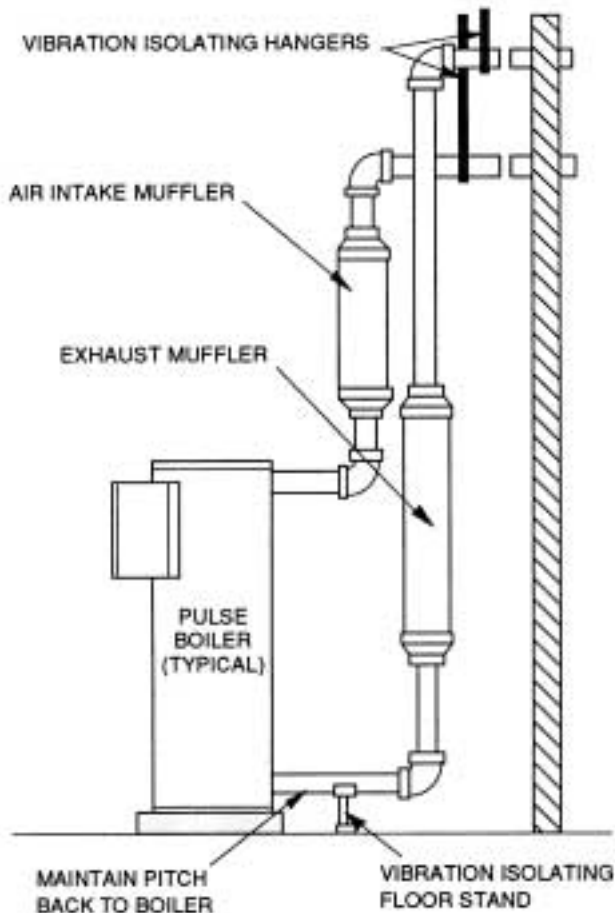

FIGURE 4.8

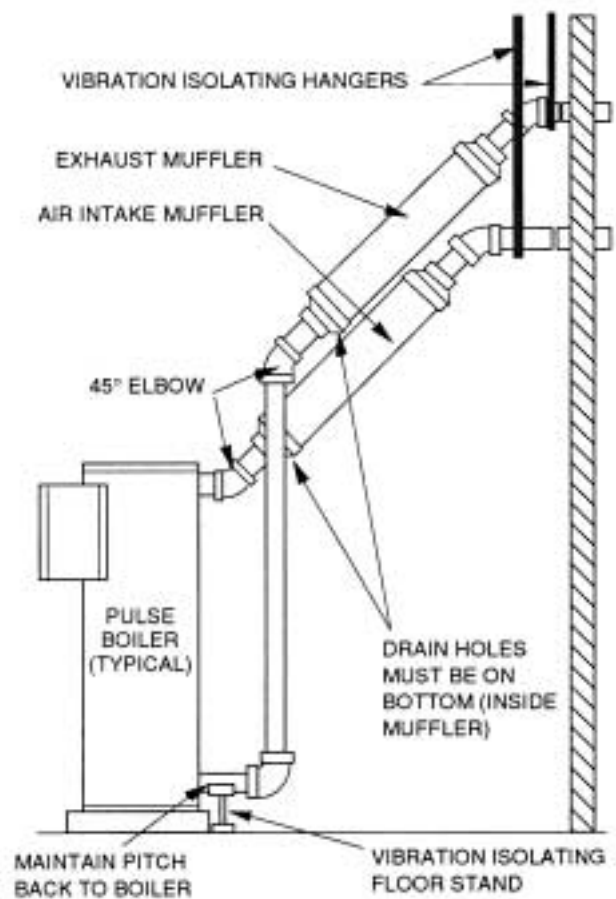

FIGURE 4.9

SECTION 5: INSTALLING CONDENSATE LINE

It is recommended that the condensate system be sealed and vented to the outdoors to prevent objectionable odors in the mechanical room. The condensate pipe must be as short as possible and pitched downward away from the boilers.

Standard Size Condensate Line without a “P” Trap: A condensate line made from 1/4" ID rubber hose or plastic tubing should be run into a floor drain or to a condensate receiver tank or pump, see Figure 5.1.

Standard Size Condensate Line with a “P” Trap: The boiler must be installed on a solid pedestal that raises it at least 5" above the floor before a “P” trap can be

installed. A condensate line made from 1/4" rubber hose or plastic tubing having a 4" “P” trap should be run into a floor drain or to condensate receiver tank or pump, see Figure 5.2.

Oversized Condensate Line with a “P” Trap: The boiler must be installed on a solid pedestal that raises it at least 7" above the floor before an oversized condensate line with a “P” trap can be installed. Install the oversized condensate line with “P” trap and run it into a floor drain or to a condensate receiver tank or pump, see Figure 5.3.

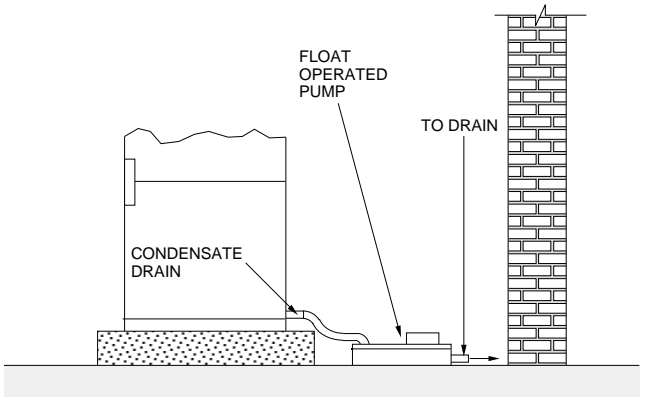

FIGURE 5.1

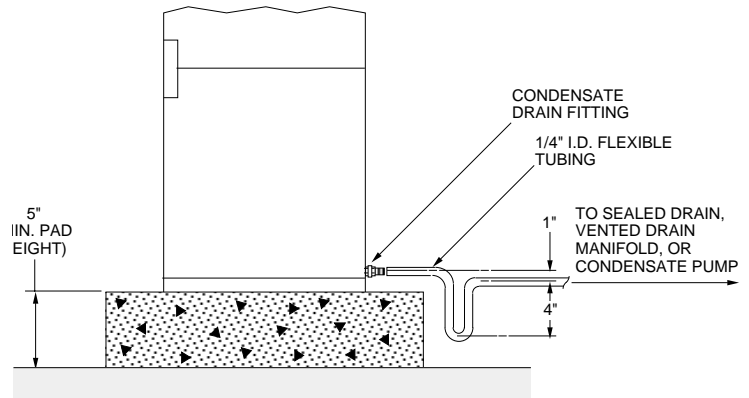

FIGURE 5.2

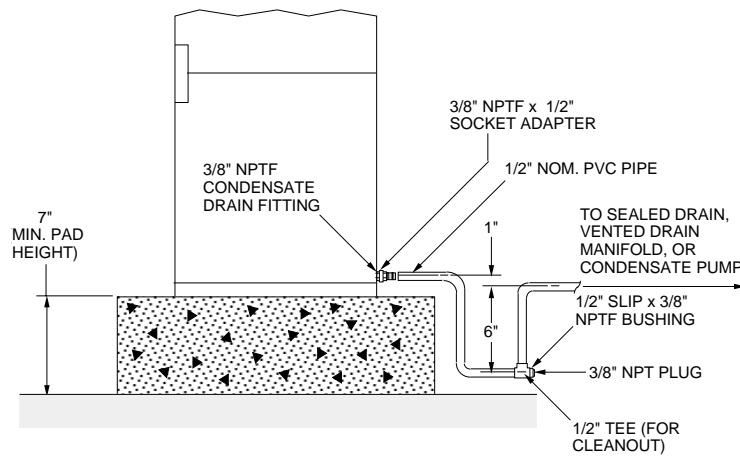

FIGURE 5.3

SECTION 6: INSTALLING GAS PIPING

SELECT GAS PIPE SIZE

Size must result in a pressure drop of less than 0.3" for natural gas or 0.5" W.C. for propane.

Example: Model AM-100 is to be installed. Distance from gas meter to installation site is 20 ft. What pipe size must be used? Utility indicates heating value of natural gas being supplied is 1000 Btu per cu.ft. Determine cubic feet of gas per hour for above model:

$$\frac{100,000 \text{ Btu per hour}}{1000 \text{ Btu per cu.ft.}} = 100 \text{ cu.ft. per hour}$$

1. Find 20 ft. in upper portion of the Table 6.1 for natural gas under "Length of Pipe, Feet" heading.
2. Moving down the column, match required capacity. Higher capacity acceptable. In our case it is 190 cu.ft.
3. Move to left-hand column "Nominal Iron Pipe Size, Inches"; read required pipe size. In our case it is 3/4".

Maximum Capacity of Pipe in Cubic Feet of Natural Gas per Hour for Gas Pressures of 0.5 Psig or Less and a Pressure Drop of 0.3 Inch Water Column
(Based on a 0.60 Specific Gravity Gas)

Nominal Iron Pipe Size, Inches	Internal Diameter, Inches	Length of Pipe, Feet													
		10	20	30	40	50	60	70	80	90	100	125	150	175	200
1/4"	.326	32	22	18	15	14	12	11	11	10	9	8	8	7	6
3/8"	.493	72	49	40	34	30	27	25	23	22	21	18	17	15	14
1/2"	.622	132	92	73	63	56	50	46	43	40	38	34	31	28	26
3/4"	.824	278	190	152	130	115	105	96	90	84	79	72	64	59	55
1"	1.049	520	350	285	245	215	195	180	170	160	150	130	120	110	100
1-1/4"	1.380	1,050	730	590	500	440	400	370	350	320	305	275	250	225	210
1-1/2"	1.610	1,600	1,100	890	760	670	600	560	530	490	460	410	380	350	320
2"	2.067	3,050	2,100	1,650	1,450	1,270	1,150	1,500	990	930	870	780	710	650	610
2-1/2"	2.469	4,800	3,300	2,700	2,300	2,000	1,850	1,700	1,600	1,500	1,400	1,250	1,130	1,050	980
3"	3.026	8,500	5,900	4,700	4,100	3,600	3,250	3,000	2,800	2,600	2,500	2,200	2,000	1,850	1,700
4"	4.026	17,500	12,000	9,700	8,300	7,400	6,800	6,200	5,800	5,400	5,100	4,500	4,100	3,800	3,500

Maximum Capacity of Pipe in Thousands of Btu per Hour of Undiluted Liquefied Petroleum Gases (at 11 Inches Water Column Inlet Pressure)
(Based on a Pressure Drop of 0.5 Inch Water Column)

Nominal Iron Pipe Size, Inches	Length of Pipe, Feet											
	10	20	30	40	50	60	70	80	90	100	125	150
1/2"	275	189	152	129	114	103	96	89	83	78	69	63
3/4"	567	393	315	267	237	217	196	185	173	162	146	132
1"	1071	732	590	504	448	409	378	346	322	307	275	252
1-1/4"	2205	1496	1212	1039	937	834	771	724	677	630	567	511
1-1/2"	3307	2299	1858	1559	1417	1275	1180	1086	1023	967	866	787
2"	6221	4331	3465	2992	2646	2394	2205	2047	1921	1811	1606	1498

TABLE 6.1

CONNECTING GAS PIPING

Connect gas piping from meter to boiler following good piping practices. Pipe joint compound must be compatible with natural or propane gas. Check local codes/utilities for any special requirements. All piping must be supported by hangers, not by boiler or its accessories.

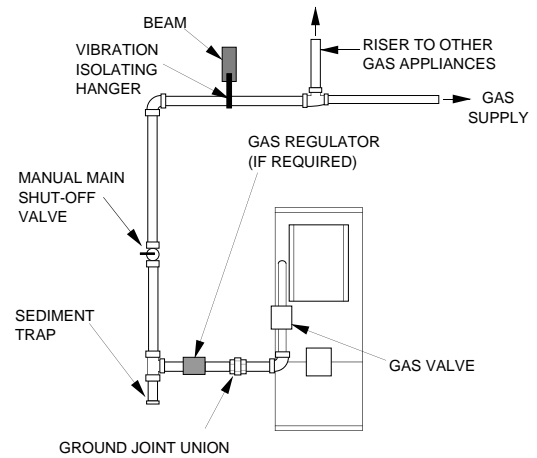

FIGURE 6.1

TESTING GAS PIPING

DANGER: Before placing gas piping into service, carefully test it to assure every joint is gas tight. Bubble test all joints with a soap solution. NEVER TEST WITH AN OPEN FLAME AS FIRE OR EXPLOSION WILL RESULT.

For any pressure testing in excess of 1/2 psi, the boiler and its individual shutoff valve must be isolated from the piping system by disconnecting them and capping the outlet(s). For any pressure testing equal to or less than 1/2 psi, the boiler must be isolated from the piping system by closing its manual shutoff valve.

Static and operating pressure required at gas valve inlet is between 4.5" and 7" W.C. for natural gas and 11" W.C. for propane. If gas pressure is above this limit, a pressure regulator must be installed, which must be a lock-up style to prevent pressure variations when boiler is not operating, see Figure 6.2. If gas pressure is below these limits, contact local utility.

For propane boilers, if reading exceeds or is less than 11" W.C., adjust regulator on propane tank or at entrance to residence.

Boiler Model	LOCK-UP STYLE GAS REGULATORS			
	Natural Gas Supply Pressure		Propane Gas Supply Pressure	
	8"-11"W.C.	11"-14"W.C.	+14"W.C.	+11"W.C.
AM-100	325-5	325-3 325-5	325-3 325-5	325-3 325-5
AM-150	RC600S	325-5	325-5	N/A

NOTE: Only Maxitrol models are shown. Other brand names with equivalent models are available.

FIGURE 6.2

SECTION 7: WIRING THE BOILER

WARNING: DO NOT ATTEMPT TO START BOILER, NOT EVEN MOMENTARILY, TO TEST WIRING BEFORE FILLING AND PURGING BOILER! DAMAGE CAUSED BY A DRY-FIRE IS NOT COVERED BY WARRANTY!

DANGER: Turn off electrical power supply before servicing. Contact with live electric components can cause shock or death.

CAUTION: Label all wires prior to disconnection when servicing controls. Wiring errors can cause improper and dangerous operation! Verify proper operation after servicing.

NOTE: If any original wire supplied with the boiler must be replaced, use similar wire of 105 C rating. Otherwise, insulation may melt or degrade, exposing bare wire.

NOTE: Boiler transformer must not be used to power external accessories such as zone valves, relays, etc. Otherwise, transformer will be overloaded and burn out.

All electrical wiring must be in accordance with the requirements of authority having jurisdiction or, in absence of such requirements, with National Electric Code NFPA -70-latest edition and any additional state or local code requirements. If an external source is utilized, installed boiler must be electrically grounded in accordance with the requirements of authority having jurisdiction or, in absence of such requirements, with National Electric Code ANSI/NFPA -70-latest edition. UL listed power limited circuit cable is almost universally approved for safety controls on heating equipment, either internally or externally, without protection of conduits or raceway.

For Canada, all electrical connections are to be made in accordance with Standard C.S.A. C22.1 Canadian Electrical Code, Part 1 and Part 2, and/or local codes.

For individual boiler wiring, refer to diagrams in Figures 7.1 & 7.2. Additional system wiring diagrams are shown in Figures 7.3 through 7.8.

A separate 115V, 60Hz power supply is recommended for the boiler. Use standard 15-amp fuse and 14-gauge wire from power supply to boiler.

Connect power supply to terminals #1 (hot) & #4 (neutral) on the line voltage block. Connect ground wire to ground screw located next to the terminal strip in the electrical control box.

To cycle circulator with thermostat, connect circulator across terminals #4 and #5 on terminal strip. If continuous circulator operation is preferred, connect circulator across terminals #3 and #4 on terminal strip.

CAUTION: Boiler & circulator must be electrically interlocked. Boiler must not be allowed to fire if circulator is not running as heat exchanger damage/failure may result.

Connect two-strand low-voltage thermostat wiring from thermostat to terminals on side of electrical control box.

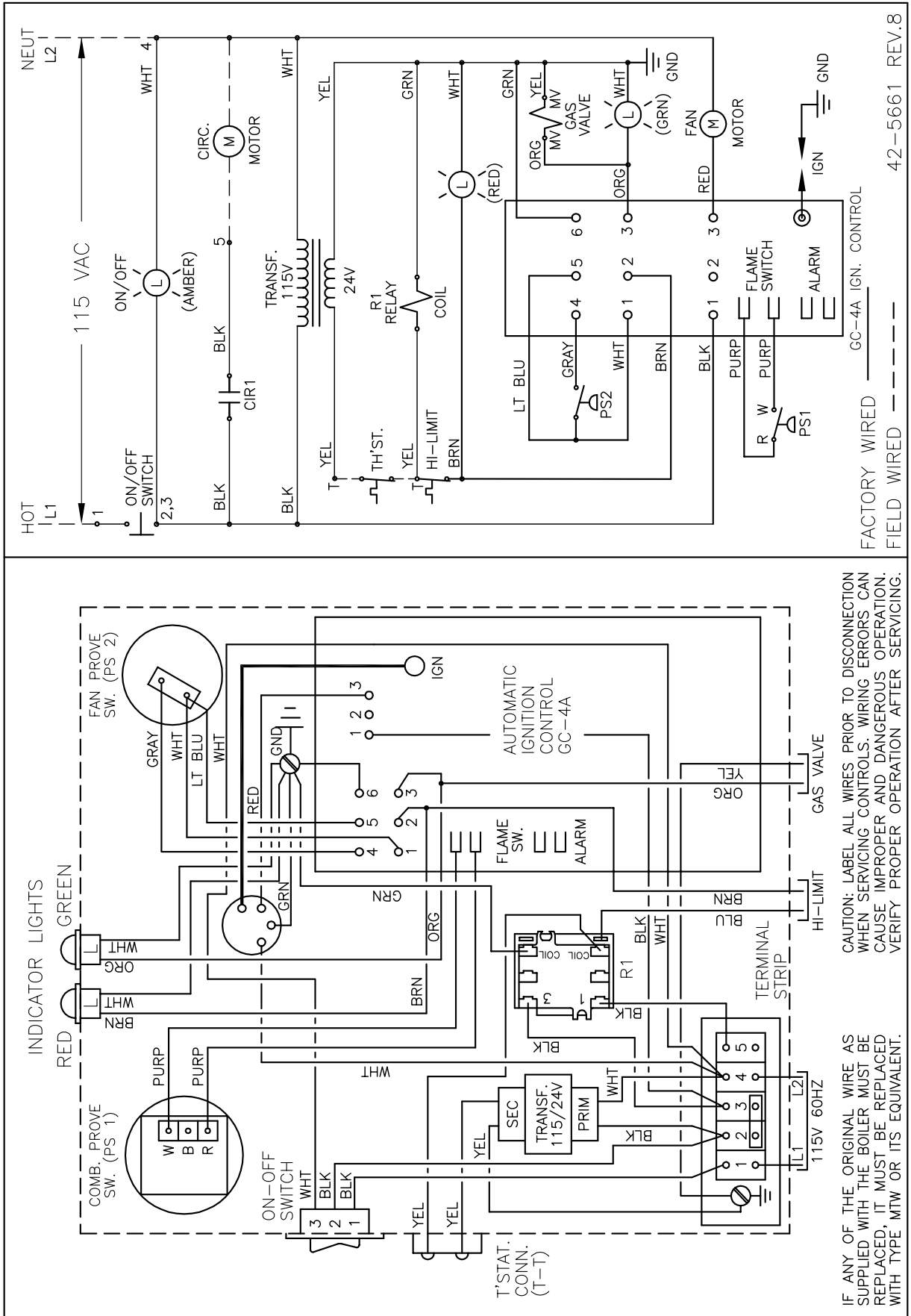
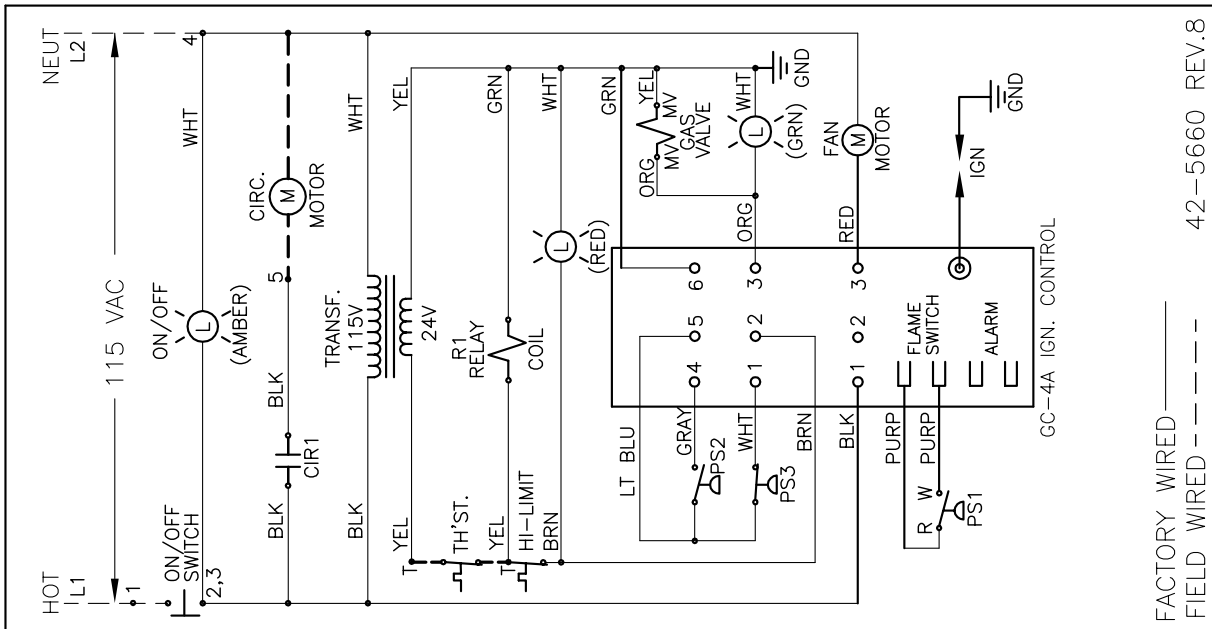
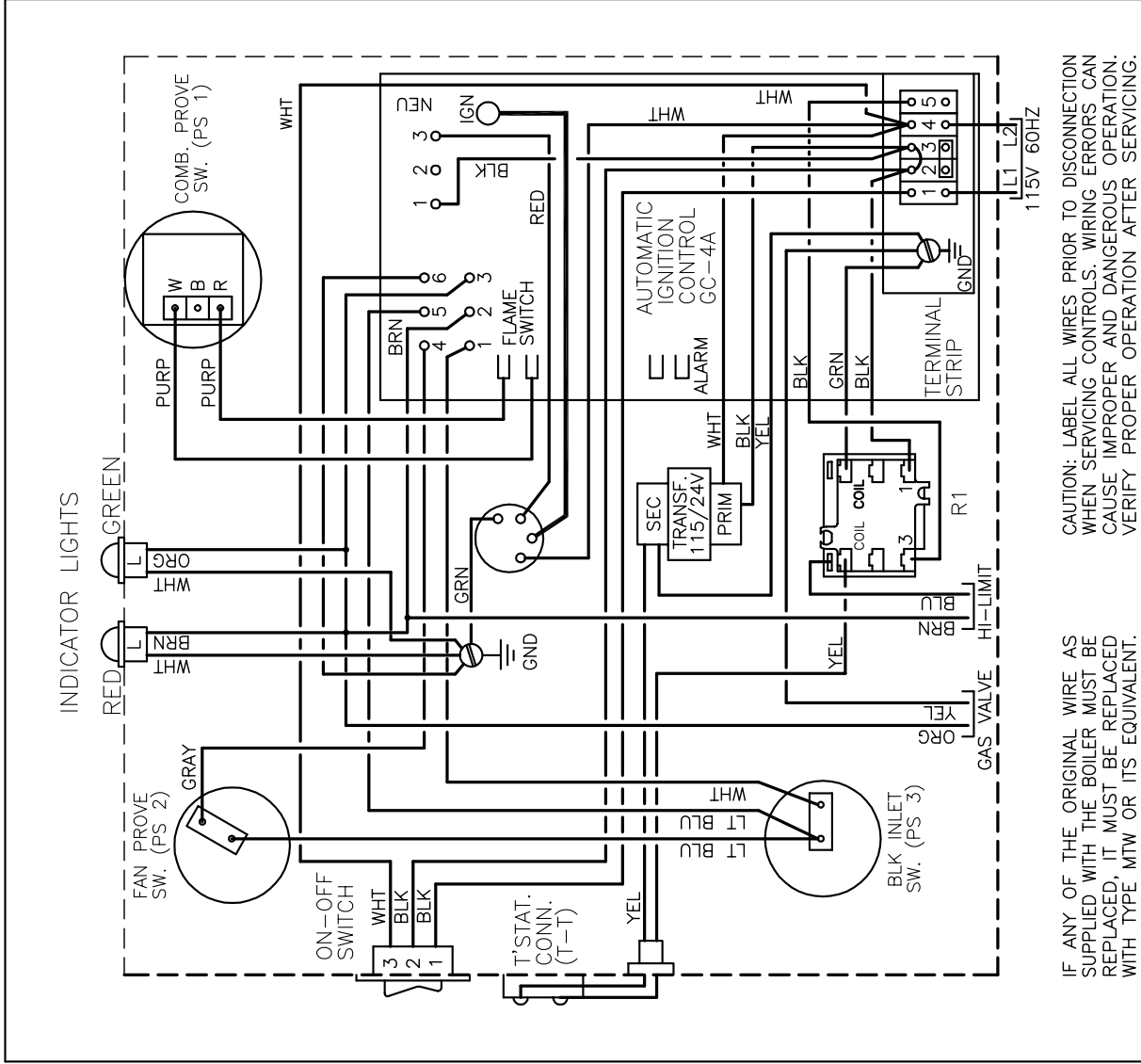

FIGURE 7.1: WIRING DIAGRAM FOR MODEL AM-100



FACTORY WIRED _____
 FIELD WIRED - - - - - 42-5660 REV.8



IF ANY OF THE ORIGINAL WIRE AS SUPPLIED WITH THE BOILER MUST BE REPLACED, IT MUST BE REPLACED WITH TYPE MTW OR ITS EQUIVALENT.

CAUTION: LABEL ALL WIRES PRIOR TO DISCONNECTION WHEN SERVICING CONTROLS. WIRING ERRORS CAN CAUSE IMPROPER AND DANGEROUS OPERATION. VERIFY PROPER OPERATION AFTER SERVICING.

FIGURE 7.2: WIRING DIAGRAM FOR MODEL AM-150

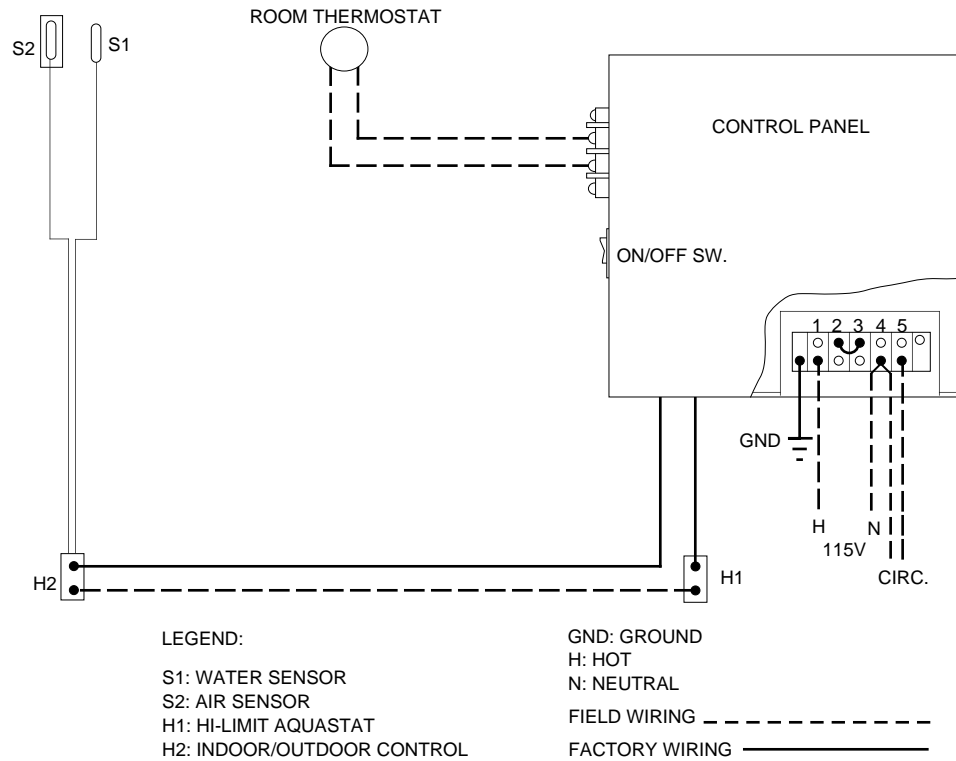

FIGURE 7.3: WIRING DIAGRAM FOR SINGLE ZONE USING HI-LIMIT AQUASTAT AND OUTDOOR RESET CONTROL

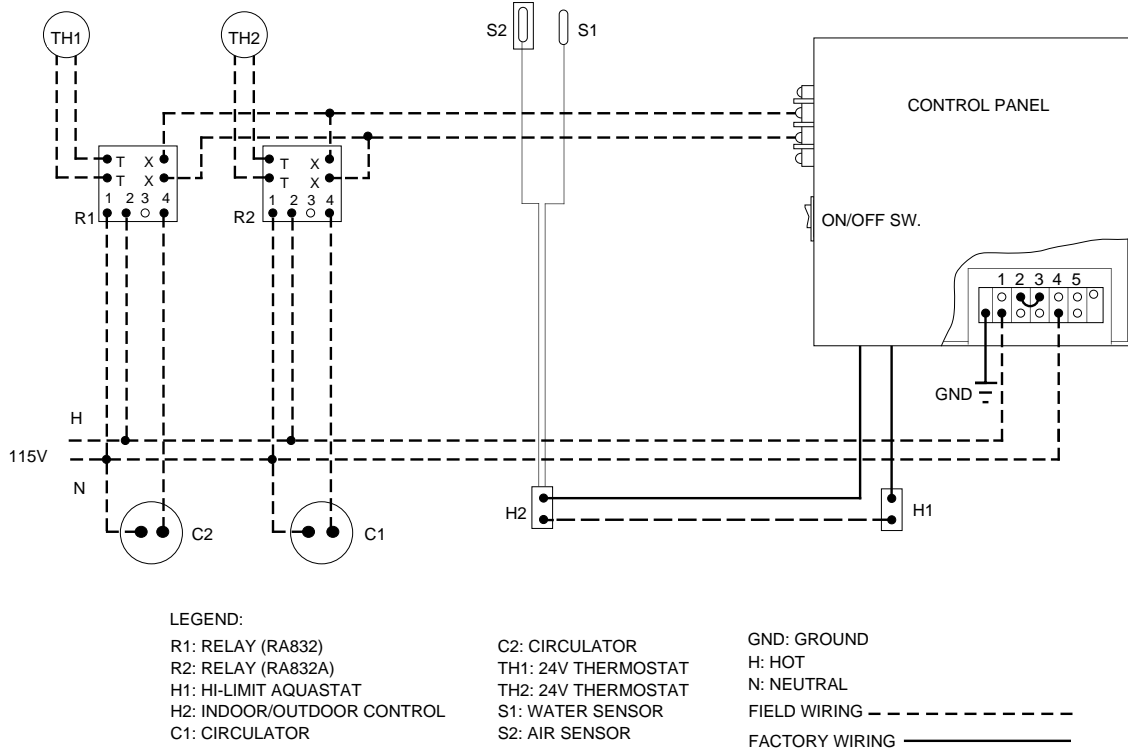
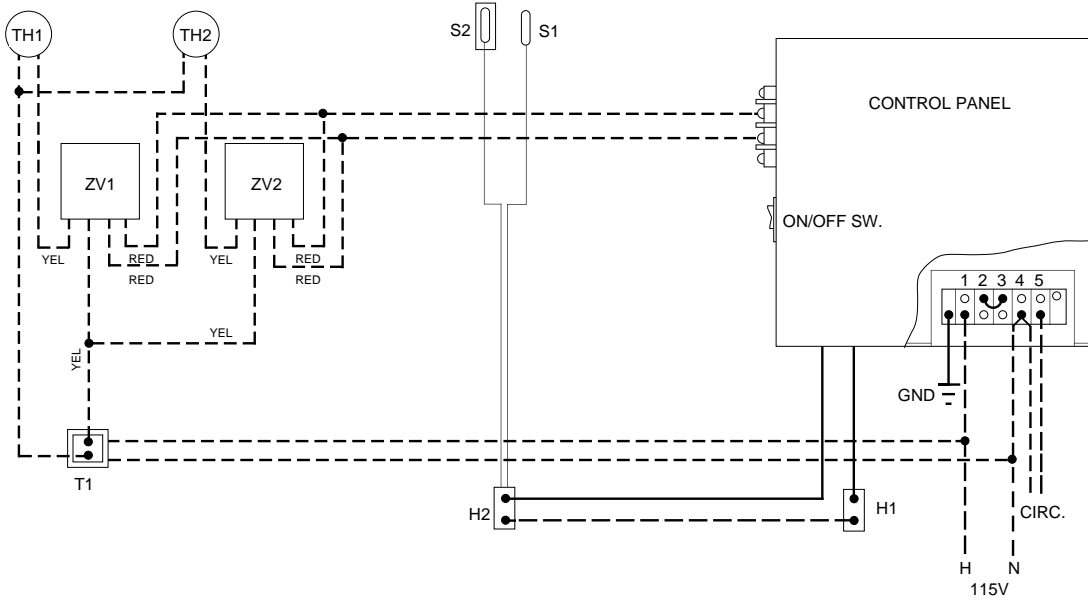
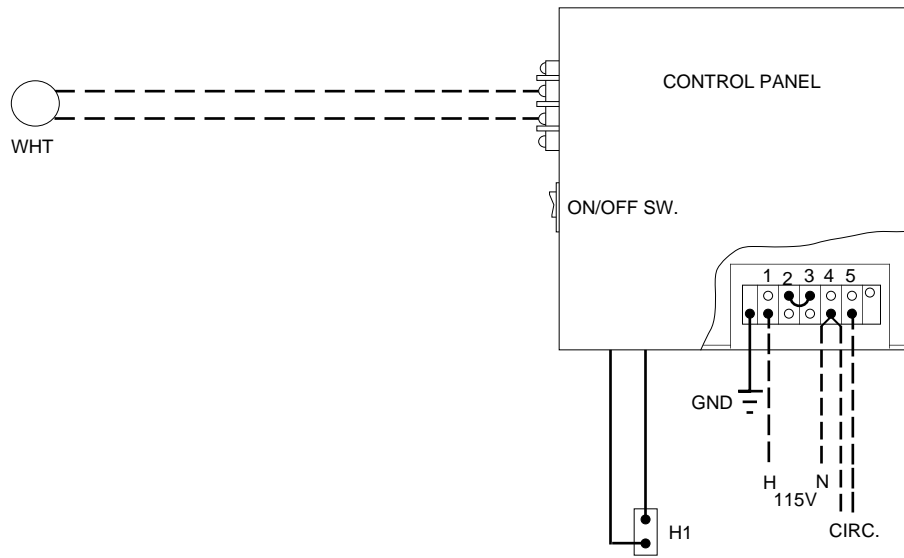

FIGURE 7.4: WIRING DIAGRAM FOR ZONING WITH CIRCULATORS AND OUTDOOR RESET CONTROL



LEGEND:
 ZV1: ZONE VALVE
 ZV2: ZONE VALVE
 H1: HI-LIMIT AQUASTAT
 H2: INDOOR/OUTDOOR CONTROL
 T1: 115/24V TRANSFORMER
 TH1: 24V THERMOSTAT
 TH2: 24V THERMOSTAT
 S1: WATER SENSOR
 S2: AIR SENSOR
 GND: GROUND
 H: HOT
 N: NEUTRAL
 FIELD WIRING - - - - -
 FACTORY WIRING _____

FIGURE 7.5: WIRING DIAGRAM FOR ZONING WITH VALVES AND OUTDOOR RESET CONTROL



LEGEND:
 H1: HI-LIMIT AQUASTAT
 WHT: WATER HEATER THERMOSTAT
 GND: GROUND
 H: HOT
 N: NEUTRAL
 FIELD WIRING - - - - -
 FACTORY WIRING _____

FIGURE 7.6: WIRING DIAGRAM FOR DOMESTIC WATER SERVICE ONLY

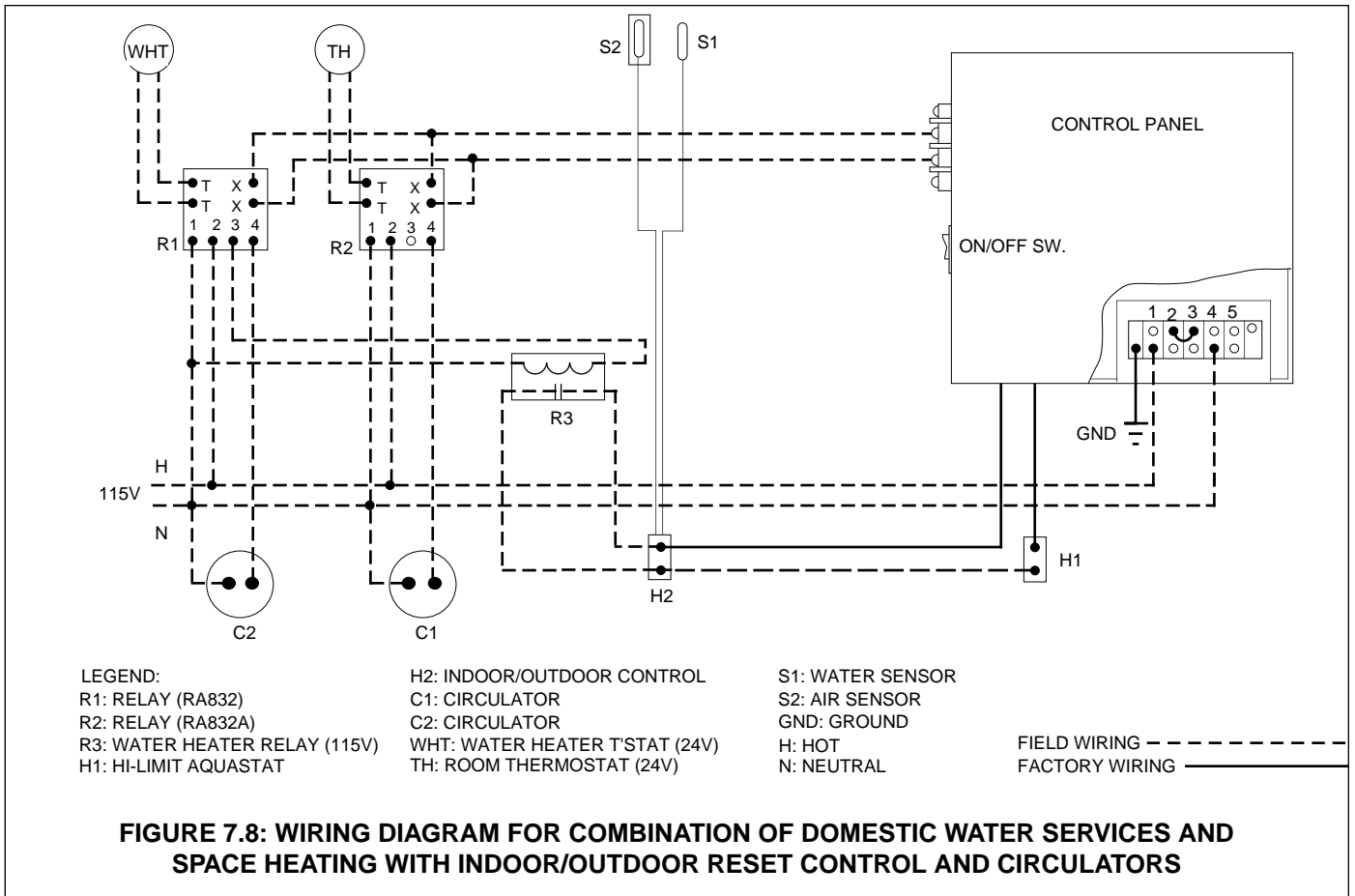
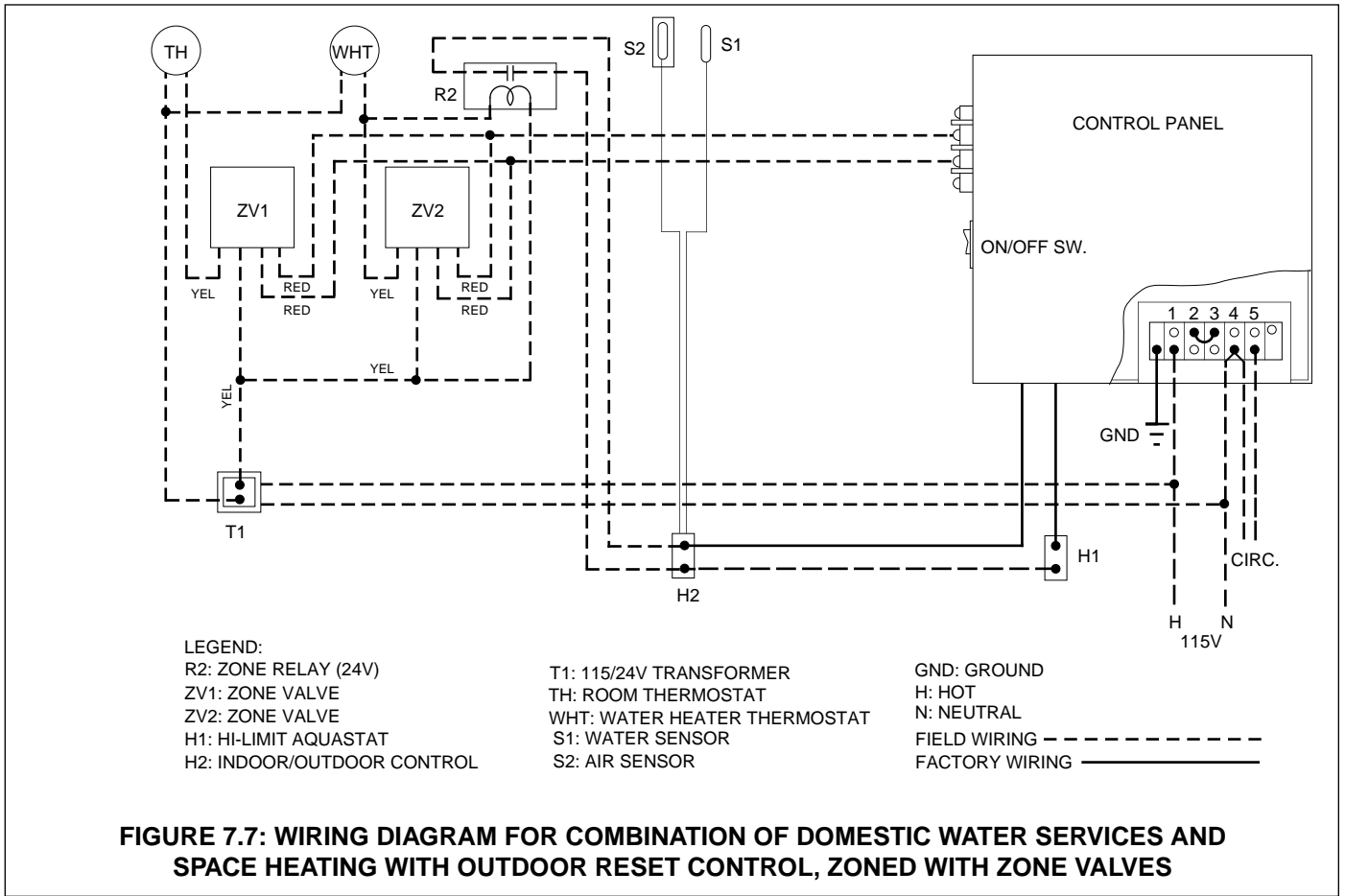

SECTION 8: START-UP & OPERATION

WARNING: DO NOT ATTEMPT TO START BOILER(S), NOT EVEN MOMENTARILY, BEFORE FILLING AND PURGING BOILER(S). DAMAGE CAUSED BY A DRY-FIRE IS NOT COVERED BY WARRANTY.

SEQUENCE OF OPERATION

1. Line switch SW1 is closed, powering 115/24v transformer. Switch light is ON.

2. Thermostat or operating control calls for heat and closes, making T-T contacts. For residential applications, circulator relay R1 is energized, powering circulator pump.

3. 24 volts is also supplied to high limit. If limit is open, GC-4A control waits. When or if limit is closed (**red indicator light comes on; green light off**), GC-4A control is energized and checks position of combustion prove switch PS1 and lockout switch PS3 on AM-150. If switch PS1 is closed, and/or switch PS3 on AM-150 is open, GC-4A control is on standby.

When or if switch PS1 is open and switch PS3 on AM-150 is closed, GC-4A control will begin attempt for ignition sequence and fan will start.

4. After approximately 35 seconds, GC-4A control will check position of fan prove switch PS2. If switch PS2 is open, fan will continue to run but there will be no attempt at ignition. If switch PS2 remains open, fan will run for 3-1/2 minutes, after which GC-4A control will go into a 15-minute wait mode, after which GC-4A control will again initiate attempt for ignition. If switch PS2 remains open, the attempt at ignition cycle will occur a total of 13 times at 15-minute intervals, after which GC-4A control will go into a lockout mode requiring a line voltage or thermostat reset.

When or if switch PS2 is closed, GC-4A control will provide a high voltage spark and open gas valve for an 8-second trial for ignition (**red indicator light on; green light comes on**).

5. Trial For Ignition: If ignition occurs during 8-second trial, the combustion chamber pressure is sensed by pressure switch PS1, closing contacts R-W and completing sensing circuit. Fan prove switch PS2 now opens; however, gas valve remains energized through

internal circuitry of GC-4A control. Fan and ignitor circuit will be de-energized when contacts R-W close. All timer circuits will be reset at the end of the heating call. (**red and green indicator lights remain on**).

If ignition does not occur during 8-second trial, spark and gas valve will shut off (**red indicator light on; green light shuts off**) but fan will continue to run. After 26 seconds, GC-4A control will check fan prove switch PS2 position. If closed, GC-4A control will initiate another 8-second trial for ignition. This sequence of 26 seconds off, 8 seconds on will occur three more times, after which gas valve, high tension spark and fan will be de-energized, leaving only the circulator running. Unit is now in a 15-minute wait mode. The attempt at ignition cycle will occur a total of 13 times at 15-minute intervals, after which GC-4A control will go into a lockout mode requiring a line voltage or thermostat reset.

6. During Run Mode: If water temperature exceeds high limit setting, limit will open and boiler will shut down (**red and green indicator lights will shut off**), leaving only the circulator running. After water temperature drops below limit set point, GC-4A control will restart ignition sequence, see Step 3.

For AM-150 Boilers Only: During run mode, if air inlet pressure in air cushion chamber drops below pressure switch PS3 setting, switch PS3 will open interrupting the internal circuitry of the blocked flue circuit in the control. At this time, the gas valve will close (**red indicator light on; green light shuts off**) and the unit will go into a 15-minute wait mode, after which the GC-4A control will initiate an attempt for ignition sequence.

7. When thermostat or operating control is satisfied, its contacts open, shutting off gas valve and circulator (**red and green indicator lights shut off**). All circuits will be reset awaiting another call for heat.

NOTE: GC-4 Ignition Control Troubleshooting Guide Has Been Provided On Page 57 In This Manual.

PURGING & START-UP PROCEDURES

NOTE: Purging procedure applies to recommended piping configurations in Part II of this manual only.

1. Close combination shut-off/purge valve in supply piping, all drain cocks, shut-off valve to pressure reducing (fill) valve, and all manual air vents.
2. Open all other system shut-off valves, one zone valve, and vent on combination shut-off/purge valve.
3. Open shut-off valve to pressure reducing (fill) valve; water will now begin to fill the system. Air will escape through vent on combination shut-off/purge valve. Continue filling until constant stream of water, free of bubbles, is discharged from the vent.
4. Close zone valve on purged loop, and open zone valve on next loop to be purged. When all air has escaped and only water is discharged, close zone valve. Repeat procedure until all zones have been individually purged. Close vent on combination shut-off/purge valve.
5. At this point, system has been initially filled. However, air pockets may still remain at all high points in the system, such as the top of the water storage tank and all heating loops above the level of the combination shut-off/purge valve. It is quite possible, depending on the particular system, that all piping above the combination shut-off/purge valve still contains nothing but air. If manual vents are installed on system high points, these should be opened to vent these locations. When only water is discharged from all vents, initial purging is complete.
6. Open combination shut-off/purge valve, but keep vent closed. **With gas shut-off valve closed**, turn on power to boiler and operate circulator. Allow system water to circulate about 25 minutes to move all air to automatic air separation point. All sounds of entrained air should be eliminated.
7. Again, open manual air vents at high points of heating loop until a constant stream of water, free of bubbles, is discharged from the vent. Close vent and make sure it's watertight. Repeat this procedure for every high point vent and for every zone.
8. Check temperature/pressure indicator reading; it should equal pressure reducing (fill) valve set pressure.

No more water should be entering the system. Close shutoff valve on cold water fill line.

9. Visually inspect all pipe joints and equipment connections for leaks. If necessary, drain system, repair leaks and re-fill/purge system. If no pressure drop is detected for a period of two hours under pressure, the system may be considered watertight.
10. When purging is completed, make sure the following are open—combination shut-off/purge valve, shutoff valve to pressure reducing (fill valve), shut-off valve in cold water fill line, and shut-off valve in return line. Make sure the following are closed— all drain cocks, vent on combination shut-off/purge valve, and all manual vents. Reset zone valves to normal mode of operation and turn off power to boiler.
11. Make sure thermostat heat anticipator is set at 1.1 amp when thermostat is controlling the boiler directly. When zone controlled, set heat anticipator to amp draw of zone valve or circulator pump relay.
12. Check that safety high limit is factory set at 190° F with a 30° F adjustable differential.
13. Open gas shut-off valve, allowing gas to flow to boiler.

WARNING: Keep boiler area clear and free from combustible materials, gasoline and other flammable vapors and liquids. Otherwise, fire or explosion may result.

14. Make sure boiler combination gas valve is in OFF position. Light the boiler following lighting instructions in Figure 8.1. Safe lighting and other performance criteria were met with the gas manifold and control assembly provided on the boiler when the boiler underwent tests specified on ANSI Z21.13-latest edition.
15. Allow system to heat up to approximately 120° F operating temperature. Shut off gas supply to boiler and allow circulator to circulate system water through all loops and zones. Repeat this procedure for each 20° F rise in operating temperature until final design operating temperature is attained. This will allow air, released from water when it's heated, to escape by means of air separation and elimination components.

WARNING:

If you do not follow these instructions exactly, a fire or explosion may result causing property damage, personal injury, or loss of life.

A. BEFORE OPERATING smell all around the appliance area for gas. Be sure to smell next to the floor because some gas is heavier than air and will settle on the floor.

WHAT TO DO IF YOU SMELL GAS

- Do not try to light any appliance.
- Do not touch any electrical switch; do not use any phone in your building.
- Immediately call your gas supplier from a neighbor's phone. Follow the gas supplier's instructions.
- If you cannot reach your gas supplier, call the fire department.

B. Use only your hand to turn the gas control knob, never use tools. If the knob will not turn by hand don't try to repair it, call a qualified service technician. Force or attempted repair may result in a fire or explosion.

C. Do not use this appliance if any part has been under water. Immediately call a qualified service technician to inspect the appliance and to replace any part of the control system and any gas control which has been under water.

OPERATING INSTRUCTIONS

THIS APPLIANCE DOES NOT HAVE A PILOT. IT IS EQUIPPED WITH AN IGNITION DEVICE WHICH AUTOMATICALLY LIGHTS THE BURNER. DO NOT TRY TO LIGHT THE BURNER BY HAND.

1. **STOP!** Read the safety information above.
2. Set the thermostat to lowest setting.
3. Turn off all electric power to the appliance.
4. This appliance is equipped with an ignition device which automatically lights the burner. Do **not** try to light the burner by hand.
5. Turn gas control knob clockwise ↻ to "OFF." Do not force.
6. Wait five (5) minutes to clear out any gas. Then smell for gas, including near the floor. If you then smell gas

STOP! Follow "A" in the safety information above. If you don't smell gas, go to the next step.

7. Turn gas control knob counterclockwise ↺ to "ON."
8. Turn on all electric power to the appliance.
9. Set the thermostat to the desired setting.
10. If the appliance will not operate, follow the instructions "To Turn Off Appliance" and call your service technician or gas supplier.

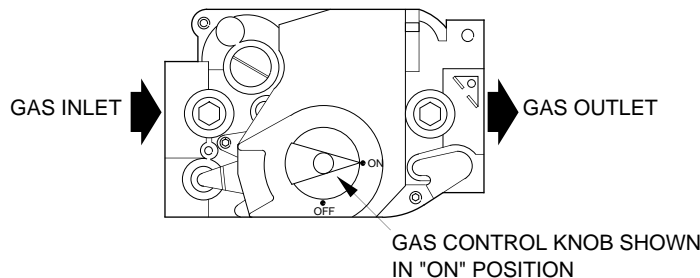

TO TURN OFF APPLIANCE

1. Set the thermostat to lowest setting.
2. Turn off all electric power to the appliance if service is to be performed.
3. Turn gas control knob clockwise ↻ to "OFF." Do not force.

FIGURE 8.1 LIGHTING INSTRUCTIONS AM-100/150/300

OPERATION ADJUSTMENTS

HIGH ALTITUDE INSTALLATIONS

A reduction of appliance input must be made to account for the effects that altitude has on available air supply to the units installed in areas exceeding 2,000 ft. elevations. This derate also affects the boiler output and flow rate specifications accordingly.

Gas input reduction is only required for elevations greater than 2,000 ft. It is to be made by reducing the pressure regulator setting (counterclockwise rotation) of the gas valve in accordance with the procedure outlined under "Operation Adjustments" of this manual.

The boiler is factory adjusted for the respective gas at the normal or "sea-level" input marked on the rating label. Refer to the instruction manual and adjustment label inside control box, before making any input pressure adjustments.

All pressure adjustments should be made with the boiler "OFF." All pressure readings should be measured with the boiler running and the gas valve regulator cap securely in place.

U.S. Installations

Use ANSI Z223.1 recommendation. For operation at altitudes above 2,000 ft. derate rating label input and resulting ratings by 4% for each 1,000 ft above sea-level.

Canada Installations

Use CAN/CGA 2.17 recommendation. For operation at altitudes between 2,000 ft. and 4,500 ft. – reduce appliance input 10% to the value shown on rating label for HIGH-ALTITUDE installations.

After completing the Canada input reductions - mark the "derate completion" box on the rating label on the appliance.

CHECK GAS INPUT RATE: After boiler has been in operation for 10 minutes, check gas input rate to boiler using one of the two following methods:

Method #1: Measure Gas Flow Input, Natural Gas Only

Make sure all other appliances served by the gas meter are turned off during timing of gas input rate. Before calculating the input of the heating equipment, obtain heating value of the gas from the local utility.

At meter, with stopwatch, measure time in seconds it takes for the boiler to use 10 cubic feet of gas. Divide 36,000 by number of seconds. This is the number of cubic feet of gas used per hour. Multiply this figure by heating value of the gas to obtain Btu input per hour.

Example: An AM-150 boiler takes 240 seconds to use 10 cubic feet of natural gas. The local utility indicated the

heating value of the natural gas being supplied is 1000 Btu/cu ft. Therefore:

$$\frac{36,000 \times 1000}{240} = 150,000 \text{ Btu/hr.}$$

Boiler input within 2% of nameplate is correct.

Method # 2: Measure Differential Pressure

Turn off boiler & combination gas valve. It is not necessary to turn off other gas appliances.

Remove plug from pressure tap in the gas line downstream from combination gas valve. Replace plug with a 1/8 NPT to 3/16" barb or flare compression adapter. Connect a piece of 3/16" tubing from adapter to either side of a manometer.

Remove downstream manifold pressure test plug from combination gas valve. Replace plug with a 1/8 NPT to 3/16" barb or flare compression adapter. Connect a second piece of 3/16" tubing from adapter to open side of manometer.

Open gas valve and turn on boiler. Remember to add the two manometer water columns together to get reading. After combustion starts, manometer should read as follows:

AM-100: 2.8" W.C. Natural Gas., 4.5" W.C. LP Gas

AM-150: 2.1" W.C. Natural Gas; 6.8" W.C. LP Gas

Refer to "High Altitude" section for exceptions.

If boiler input needs to be corrected, turn off boiler, remove cap on combination gas valve pressure regulator screw, and adjust regulator. Regulator is factory set according to differential pressure above. Turn adjusting screw clockwise to increase gas flow (increase input); counterclockwise to decrease gas flow (decrease input). Replace cap on adjusting screw, tighten securely, and turn on boiler. In no case should final differential pressure setting vary more than ± 0.3 " W.C. from factory-set pressures unless an additional altitude adjustment is required. If rated input cannot be obtained with regulator adjustment, gas supply pressure may be the cause. Consult local utility.

IN SUSPECTED HIGH GAS PRESSURE AREAS: It's good practice to check line pressure with a manometer. Turn off boiler & gas supply to gas valve.

Remove supply pressure test plug on combination gas valve. Replace plug with a 1/8 NPT to 3/16" barb or flare compression adapter. Connect a piece of tubing from the adapter to either side of manometer.

Open gas supply to combination gas valve and record supply pressure. Turn on boiler. After combustion starts,

OPERATION ADJUSTMENTS (Continued)

manometer should read 4.5" to 7.0" W.C for natural gas or 11" W. C. for propane.

If the two readings vary by more than 2.0" W.C., gas piping needs to be reviewed for proper size and for restrictions to flow.

For natural gas boilers, if reading exceeds 7.0" W.C., install regulator upstream of gas valve to reduce street pressure. If reading is less than 4.5" W.C., contact local utility for recent line pressure reductions.

For propane boilers, if reading exceeds or is less than 11" W.C., adjust regulator on propane tank or at entrance to the residence.

CHECK WATER FLOW: After the system has been brought up to final design operating temperature, check temperature rise across the boiler. Read return water temperature with a strap-on thermometer and compare to temperature/pressure indicator reading during boiler operation. A temperature difference in excess of 60-degrees is an indication that water flow rate is below

required minimum.

CHECK OPERATION OF CONTROLS: Start and stop boiler several times by raising and lowering the control setting.

After boiler(s) have been firing long enough to raise boiler water temperature above minimum setting of high limit, check boiler's high limit by turning its setting from maximum to minimum. This should turn the boiler off. Return high limit to desired setting.

Check ignition safety circuit on boiler. With boiler firing, remove one of the purple high voltage sensor leads from the solid state control or from pressure switch PS1. The gas valve should close and boiler should cease operation. Turn power off and reconnect the lead.

WARNING: High voltage is present in control box. Use extreme care to avoid touching exposed wire connections or electrical shock will result.

MAINTENANCE

This boiler has been designed to provide years of trouble-free performance in normal installations. Examination by the homeowner at the beginning of each heating season, and in mid-heating season, should assure continued good performance. In addition, the boiler should be examined by a certified Pulse service professional at least once a year.

DANGER: To avoid fire or explosion hazards, do not store anything against the boiler or allow dirt or debris to accumulate in the area immediately surrounding the boiler. Keep boiler area clear and free from combustible materials, gasoline and other flammable vapors and liquids. Lint, paper or rags must not be allowed to accumulate near the burners. Do not place clothing on boiler casing to dry.

NOTE: Do not draw water from heating system for cleaning. Minerals in water can build up on heat transfer surfaces and cause overheating and subsequent failure of the heat exchanger.

NOTE: If boiler is equipped with a low water cut-off, follow manufacturer's maintenance instructions.

BEFORE EACH HEATING SEASON

1. Check air intake and exhaust piping for sagging and broken tube hanger straps.
2. Check air intake and exhaust outlets for any blockage or restrictions.
3. Lubricate circulator motor according to manufacturer's instructions. This information may be contained in labeling on the circulator frame.
4. Check temperature/pressure indicator to assure there is 10 to 12 psi in boiler to prevent dry-fire condition.
5. Follow "System Start-Up & Adjustments" procedures in Section 8 of this manual.
6. With the boiler running, check all air intake/exhaust piping and fittings for audible leaks, visible cracks or unsealed joints.

SECTION 9: TROUBLESHOOTING

CAUTION: Label all wires prior to disconnection when servicing controls. Wiring errors can cause improper and dangerous operation. Verify proper operation after servicing.

GC-4A IGNITION CONTROL

If boiler is having operational difficulties, and you suspect the GC-4A ignition control is defective, follow these troubleshooting procedures first, **BEFORE REPLACING THE CONTROL**. A green light, located on the GC-4A control, is visible through a hole in the

detent on the control cover. If line voltage to boiler is off or if there is no call for heat or if the hi-limit is open, the green light on the GC-4A will be off. The light will come on within 5 seconds after a call for heat (24v to control) is initiated.

GC-4A Control Light Is OFF

1. Check that amber boiler switch light is ON. If switch light is OFF, check 110v power supply to boiler.
2. If switch light is ON, check that red boiler indicator light is ON. If red light is OFF, check thermostat, hi-limit and other operational controls.
3. If red light is ON, turn boiler power supply off. Remove six-pin connector from GC-4A. Turn power supply on. Check for 24v from connector pin #2 (brown wire) to a ground. If OK, reconnect it to GC-4A. If green GC-4A control light does not come on within 5 seconds, control is defective; replace it.

GC-4A CONTROL LIGHT IS ON

1. Observe light for 3-1/2 minutes (one attempt-for-ignition cycle).
2. If light remains ON, but not blinking, turn power to boiler off. Remove one purple lead from combustion prove pressure switch PS1 and check contacts for continuity. If circuit is closed, replace the pressure switch. If circuit is open, GC-4A control is defective; replace it.
3. On AM-150, remove a lead from the blocked inlet pressure switch PS3 and check contacts for continuity. If circuit is open, replace the pressure switch. If circuit is closed, GC-4A control is defective; replace it.

GC-4A CONTROL LIGHT BLINKS (Red Boiler Indicator light ON)

1. Blinking light indicates control is operational; problem is elsewhere in boiler. However, gas valve circuit and GC-4A ignitor should be checked. Turn boiler on/off switch off and on; this will reset GC-4A control and start an attempt-for-ignition cycle. From 25 to 40 seconds after resetting GC-4A, check that green boiler indicator light comes ON.
2. If green indicator light remains OFF, turn power to boiler off. Turn power to boiler on. Place jumper across fan prove pressure switch PS2 terminals. After 25 to 40 seconds, check green indicator light ON. If green indicator light remains OFF, GC4A control is defective; replace it.
3. If green indicator light comes ON, check fan for proper operation and/or fan prove pressure switch PS2; replace as necessary. Also check ignition transformer as follows: Turn power to boiler off. Remove ignition lead from spud on the GC-4A control. Turn power to boiler on. After 25 seconds, when green indicator light comes ON, check for a spark with insulated screwdriver between control ignition spud and a ground. If spark is present, GC-4A is operating satisfactorily; refer to Troubleshooting Guide to correct problem. If there is no spark, check that white wire from quick connect fitting adjacent to control ignition spud to power supply neutral is securely fastened; if securely fastened and there is no spark, GC-4A control is defective; replace it.

THE HYDROTHERM CORPORATION

AM SERIES PULSE BOILER LIMITED WARRANTY

(Models AM-100, AM-150, AM-300)

ONE YEAR WARRANTY

The "Manufacturer" warrants to the original owner at the original installation site that the AM Pulse water boiler (the "Product") will be free from defects in material or workmanship for one (1) year from the date of installation or eighteen (18) months from the date of shipment from the factory, whichever comes first. If upon examination by the Manufacturer the Product is shown to have a defect in material or workmanship during the warranty period, the Manufacturer will repair or replace, at its option, that part of the Product which is shown to be defective.

FIVE YEAR WARRANTY

The Manufacturer further warrants to the original owner at the original installation site that the Product's heat exchanger subassembly will be free from defects in material or workmanship for five (5) years from the date of shipment from the factory. If upon examination by the Manufacturer the Product is shown to have a defect in material or workmanship during the warranty period, the Manufacturer will repair or replace, at its option, that part of the Product which is shown to be defective.

TWENTY YEAR WARRANTY (for residential applications only)

The Manufacturer further warrants to the original owner at the original installation site that the Product's heat exchanger subassembly will be free from defects in material or workmanship for twenty (20) years from the date of shipment from the factory. If upon examination by the Manufacturer the heat exchanger is shown to have a defect in material or workmanship during the warranty period, the Manufacturer will replace the heat exchanger subassembly upon the payment of a percentage of Manufacturer's trade price in effect at the time of the claim prorated to the year in which the claim is made, as shown below.

REPLACEMENT COST SCHEDULE

Year of Claim	6	7	8	9	10	11	12	13	14	15	16	17	18	19	20
% of trade price, at time at claim charged to consumer	21	22	23	24	25	30	35	40	45	50	55	60	65	70	75

THIS LIMITED WARRANTY DOES NOT APPLY:

- (a) if the Product has been subjected to misuse or neglect, has been accidentally or intentionally damaged, has not been installed, maintained or operated in accordance with the furnished written instructions, or has been altered or modified in any way by any unauthorized person.
- (b) to any expenses, including labor or material, incurred during removal or reinstallation of the Product or parts thereof.
- (c) to Products which were not installed and/or serviced by a certified Pulse installer and/or serviceman.
- (d) to burners, jackets, controls, and other auxiliary equipment furnished by the Manufacturer, but manufactured by others. Any warranties for such items shall be limited to those warranties offered by the original equipment manufacturer.
- (e) to any workmanship of any installer of the Product.

THIS LIMITED WARRANTY IS CONDITIONAL UPON:

- (a) shipment, to the Manufacturer, of that part of the Product thought to be defective. Goods may only be returned with the prior written approval of the Manufacturer. All returns must be freight prepaid.
- (b) determination in the reasonable opinion of the Manufacturer that there exists a defect in material or workmanship.
- (c) the residential water boiler having been installed in a single-family or two-family residential dwelling.

Repair or replacement of any part under this Limited Warranty shall not extend the duration of the warranty with respect to such repaired or replaced part beyond the stated warranty period.

THIS LIMITED WARRANTY IS IN LIEU OF ALL OTHER WARRANTIES, EITHER EXPRESS OR IMPLIED, AND ALL SUCH OTHER WARRANTIES, INCLUDING WITHOUT LIMITATION IMPLIED WARRANTIES OF MERCHANTABILITY OR FITNESS FOR A PARTICULAR PURPOSE, ARE HEREBY DISCLAIMED AND EXCLUDED FROM THIS LIMITED WARRANTY. IN NO EVENT SHALL THE MANUFACTURER BE LIABLE IN ANY WAY FOR ANY CONSEQUENTIAL, SPECIAL, OR INCIDENTAL DAMAGES OF ANY NATURE WHATSOEVER, OR FOR ANY AMOUNTS IN EXCESS OF THE SELLING PRICE OF THE PRODUCT OR ANY PARTS THEREOF FOUND TO BE DEFECTIVE. THIS LIMITED WARRANTY GIVES THE OWNER AT THE ORIGINAL INSTALLATION SITE SPECIFIC LEGAL RIGHTS. YOU MAY ALSO HAVE OTHER RIGHTS WHICH MAY VARY BY EACH JURISDICTION

260 NORTH ELM STREET
WESTFIELD, MA 01085
TEL: (413) 568-9571
FAX: (413) 568-9613

HydroTherm[®]

5211 CREEKBANK ROAD
MISSISSAUGA, ONTARIO L4W 1R3
TEL: (905) 625-2991
FAX: (905) 625-6610